

Draco- minor Switch

**Multifunctional device:
Usable as:**

- **Multiplex Repeater**
- **Crosspoint Switch**
- **Single-Head KVM-Switch**
- **Dual-Head KVM-Switch**

Type:

- K459-7C**
- K459-7M**
- K459-7S**
- K459-7X**

(Quick Setup)

1 Quick Setup

This section briefly describes how to install your Draco minor Switch system. Unless you are an experienced user, we recommend that you follow the full procedures described in the rest of this manual. You can download the manual at http://www.ihse.de/pdf/b459-xx_e.pdf.

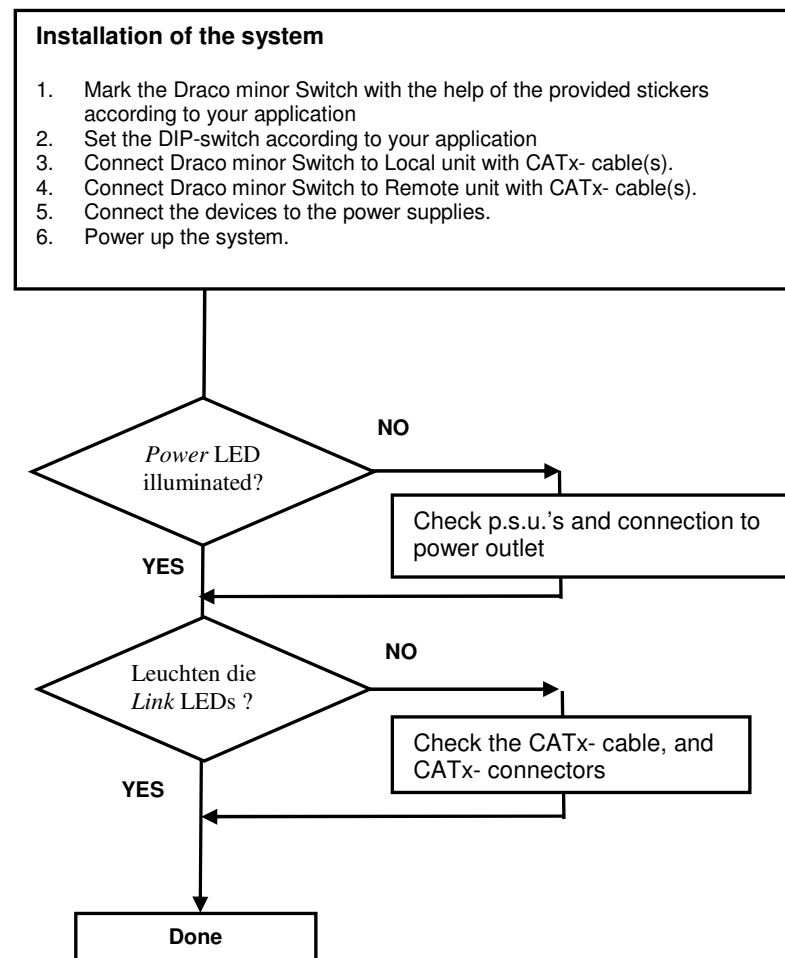

2 Installation

For first-time users, we recommend that you carry out a test placement, confined to a single room, before commencing full installation. This will allow you to identify and solve any cabling problems, and experiment with the Draco-minor System more conveniently.

2.1 Package Contents

You should receive the following items in your Draco-minor Switch for CATx package:

- Draco-minor Switch
- 1x 5V DC universal power supply for the Draco-minor Switch
- 1x serial cable RJ45 / DB9Female
- 1x German type power cord
- 1x sheet of product stickers
- User manual (Quick Setup)

If anything is missing, please contact Technical Support.

2.2 System Setup

To install your Draco-minor Switch system:

1. Switch off all devices.
2. Connect your keyboard, monitor(s) and mouse to the Remote Unit (depending on device type).
3. Connect the CPU/signal source to the Local Unit using the supplied cable(s).
4. Attach the connection cables (CATx- cable) between Draco-minor switch and Local Unit and between Draco-minor switch and Remote Unit.

Connection options:

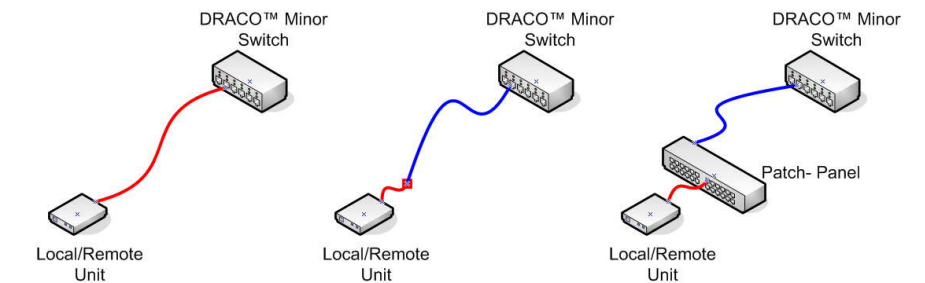

5. Take the Draco-minor switch from the packing and also the sheet with the product stickers.

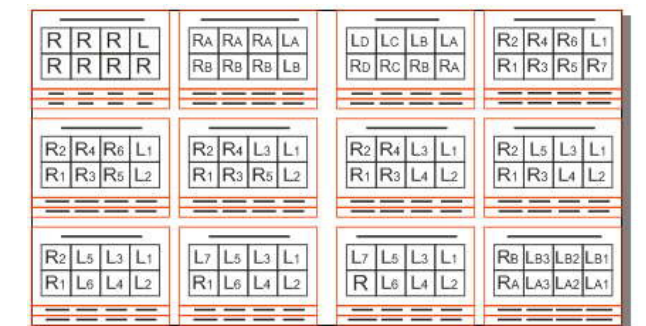

6. Loosen the corresponding sticker to your application area from the sheet and stick it on the intended place:

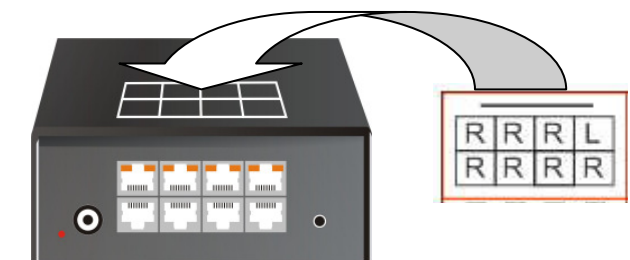

DRACO- MINOR SWITCH

- Loosen the stickers below for the inscription of the interfaces and stick it on the intended place:

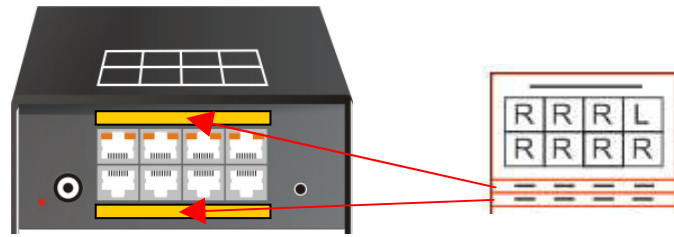

- Set the DIP-switch to the adjustment, which corresponds to your desired application. Closer information for the DIP switch set-up can be found in the manual.

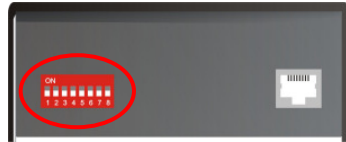

- Depending upon your application it can be necessary that you make a connection to a controller over the serial interface. Attach in addition the provided RJ45 to DSUB 9-pin cable at the socket of the serial interface and connect it with your controller. More information for control through the serial interface can be found in the manual.

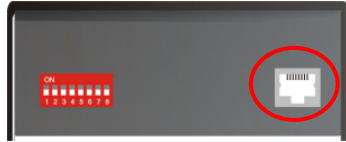

- Connect the 5V power supplies to the units.



Only use the power supply originally supplied with this equipment or a manufacturer-approved replacement.

- For a dual access system, connect the monitor for the local console to the appropriate port on the Local Unit. The port may also be used to feed into a KVM switch.

To attach a local (USB-) keyboard/mouse, please use additional USB port(s) at your CPU or use an USB hub in-between CPU and Local Unit's USB- connector.

- Power up the system.

2.3 Interconnection Cable Requirements

To connect the Draco-Media Local Unit to your CPU/signal source you will need (Please ensure that the connection is tension-free!):

DVI: Connect the supplied DVI- cable 1,8m (DVI-I male to DVI-I male) to your CPU (KVM-Switch, DVI- signal source, etc.).

To connect the Draco- KVM Local Unit to your CPU/signal source you will need (Please ensure that the connection is tension-free!):

DVI: Connect the supplied DVI-cable 1,8m (DVI-I male to DVI-I male) to your CPU (KVM-Switch, DVI- signal source, etc.).

USB: Connect the supplied USB- cable 1,8m (USB Type A to USB Type B) to your CPU (KVM- Switch, DVI- signal source, etc.).

To connect the Draco- KVM Local Unit with serial/audio you will additionally need (Please ensure that the connection is tension-free!):

Serial cable: Connect the supplied serial cable to your CPU/signal source.

Audio cable: Connect the supplied audio cable to your CPU.

CATx- cable: Recommended cable: S/UTP (Cat5) according EIA/TIA 56A, TSB 36 or Digital STP 17-03170. Four pairs AWG 24. Wiring according EIA/TIA 568A (10BaseT). Use of cables from a higher category (Cat5e, Cat6, Cat7) is possible.

manual: http://www.ihse.de/pdf/b459-xx_e.pdf

DRACO- MINOR SWITCH

The use of unshielded CATx- cable is possible; because of the higher electromagnetic noise/sensitivity the device class may not be reached.



The use of flexible cables (patch cable) type AWG26/8 is possible. Because of the higher loss of the stranded cables, the maximum distance is reduced to app. half the value of solid cables.



A point to point connection is required. Having one or more patch panels in the line is possible and allowed. Not allowed is a connection from the CATx- link interface (RJ45) to any other products, especially telecommunications or network equipment.



For the connection of the Local Unit to the Draco-minor Switch and Remote Unit to the Draco-minor Switch you will need the supplied cross cables! A direct connection at EIA/TIA wiring is NOT possible!

Power Supply: Connect the supplied 5V/DC power supplies to the *Plug* terminal on the rear of Draco Local Unit, Draco-minor Switch or Draco- Remote Unit.

3 Geräteansichten

3.1.1 Configuration 'Multiplex-Repeater (MR)' – 1 Source up to 7 Displays

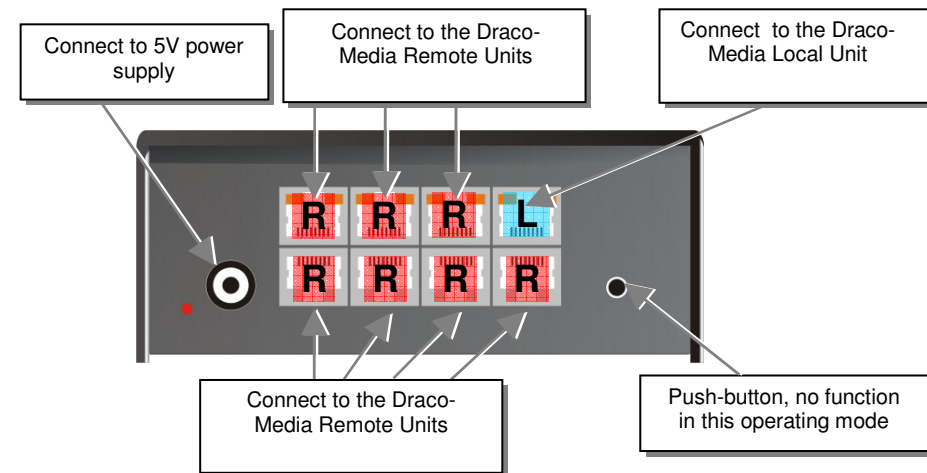

Draco-minor Switch – as 1to7 Multiplex-Repeater

3.1.2 Configuration 'MR' – 2 Sources / each up to 3 Displays

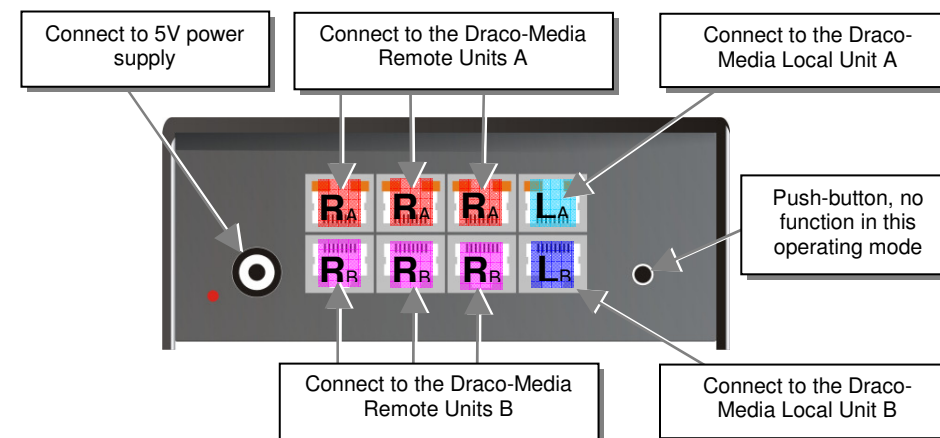

Draco-minor Switch – as 2x(2to3) Multiplex-Repeater

manual : http://www.ihse.de/pdf/b459-xx_e.pdf

DRACO- MINOR SWITCH

3.1.3 Configuration 'MR' – 4 Sources on 4 Displays

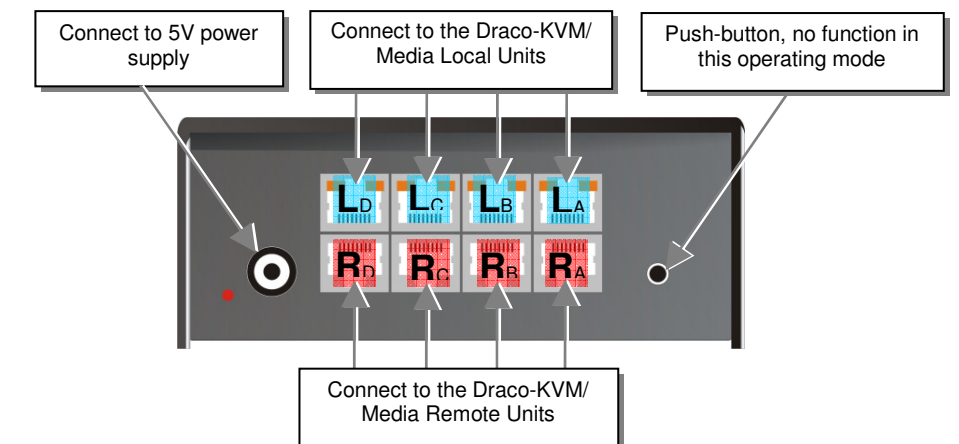

Draco-minor Switch – as 4x 1to4 Multiplex- Repeater

3.1.4 Configuration 'Crosspoint-Switch (CPS)' 1 Input / 7 Outputs

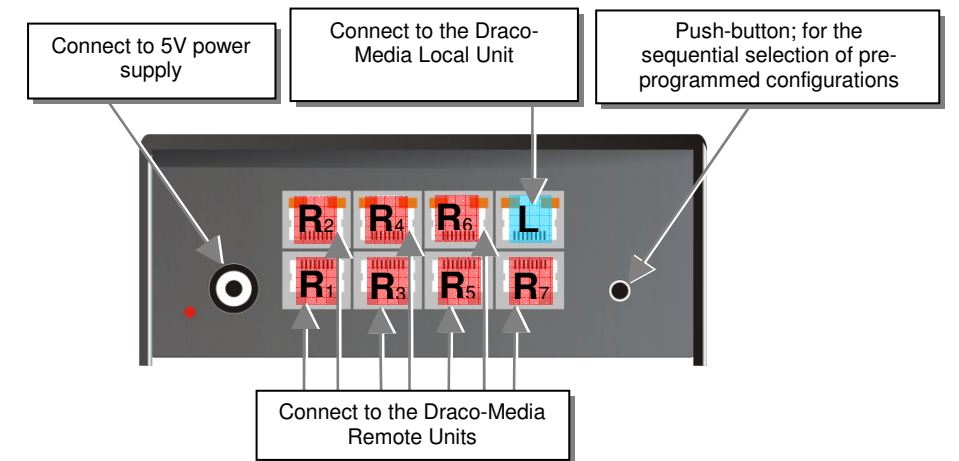

Draco-minor Switch – as Crosspoint-Switch 1x7

3.1.5 Configuration 'CPS' 2 Inputs / 6 Outputs

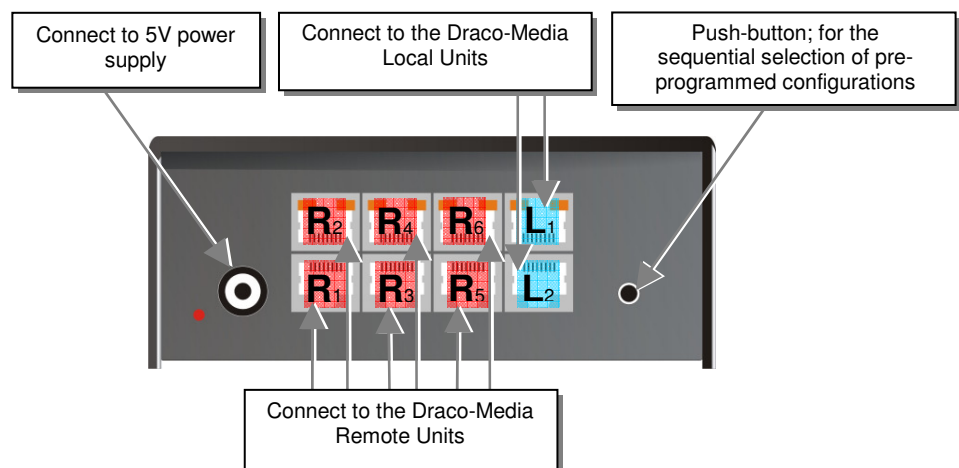

Draco-minor Switch – as Crosspoint-Switch 2x6

manual : http://www.ihse.de/pdf/b459-xx_e.pdf

DRACO- MINOR SWITCH

3.1.6 Configuration 'CPS' 3 Inputs / 5 Outputs

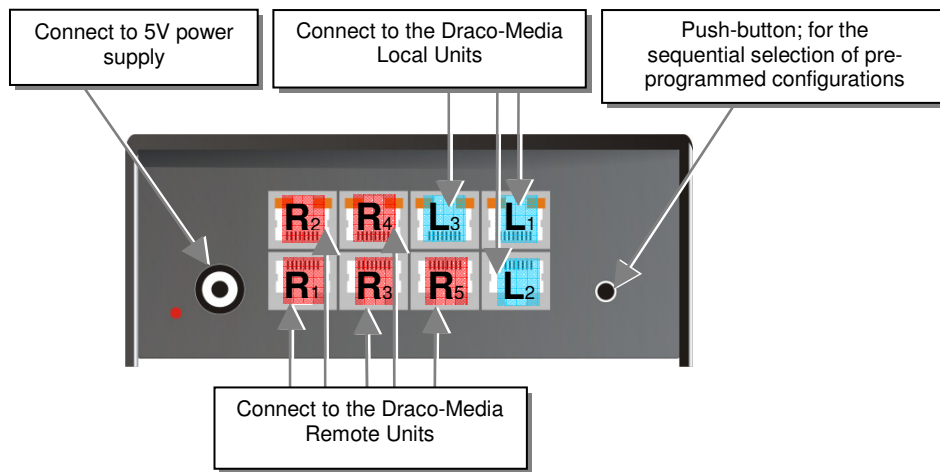

Draco-minor Switch – as Crosspoint-Switch 3x5

3.1.7 Configuration 'CPS' 4 Inputs / 4 Outputs

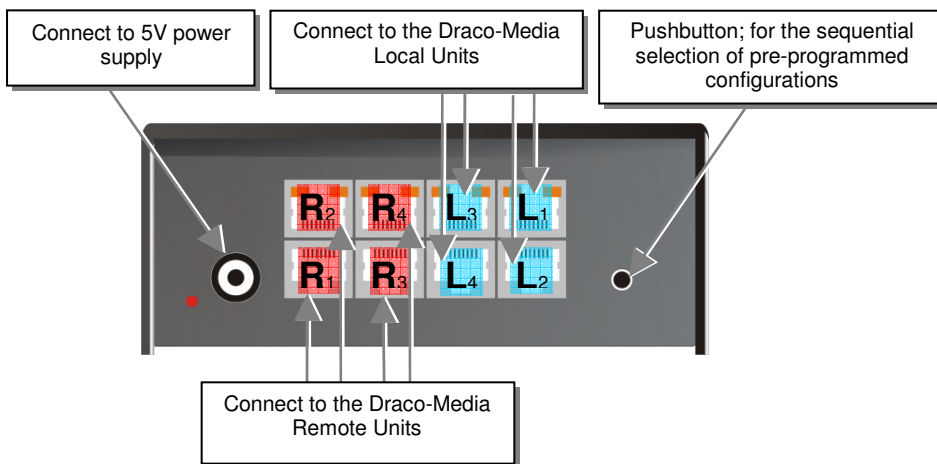

Draco-minor Switch – as Crosspoint-Switch 4x4

3.1.8 Configuration 'CPS' 5 Inputs / 3 Outputs

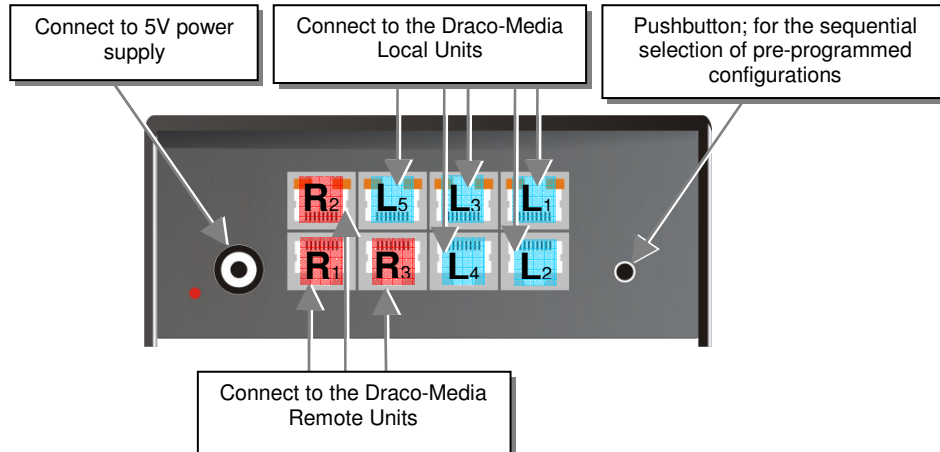

Draco-minor Switch – as Crosspoint-Switch 5x3

DRACO- MINOR SWITCH

3.1.9 Configuration 'CPS' 6 Inputs / 2 Outputs

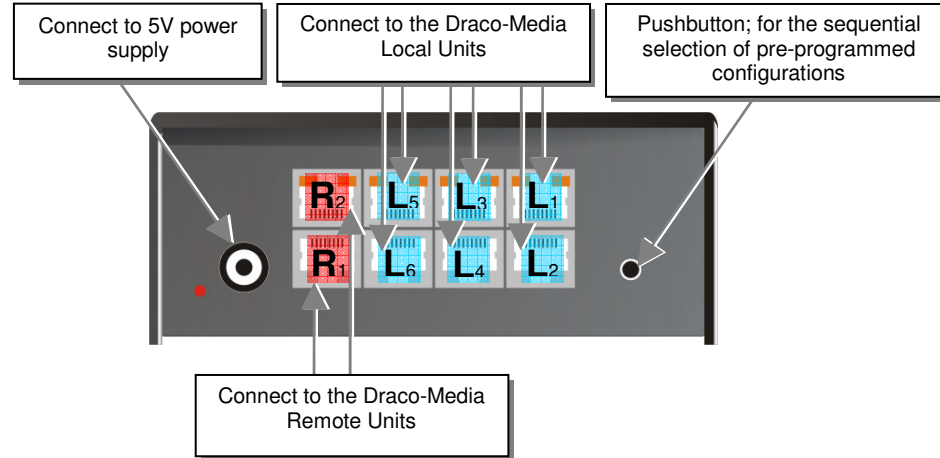

Draco-minor Switch – as Crosspoint-Switch 6x2

3.1.10 Configuration 'CPS' 7 Inputs / 1 Output

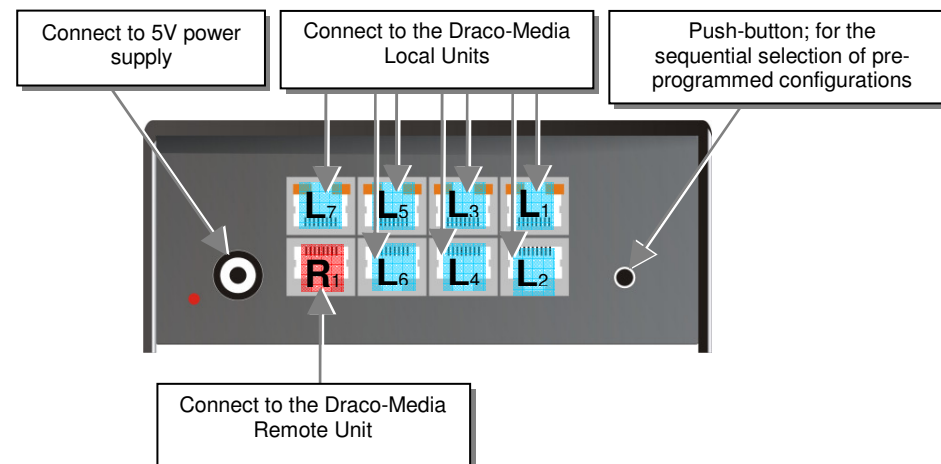

Draco-minor Switch – as Crosspoint-Switch 1x7

3.1.11 Configuration 'Single-Head KVM-Switch'

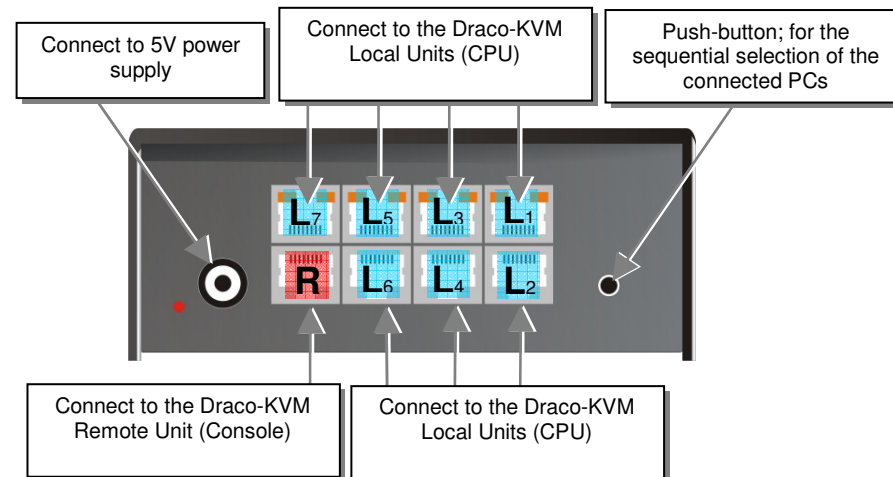

Draco-minor Switch – as Single-Head KVM-Switch

DRACO- MINOR SWITCH

3.1.12 Configuration 'Dual-Head KVM-Switch'

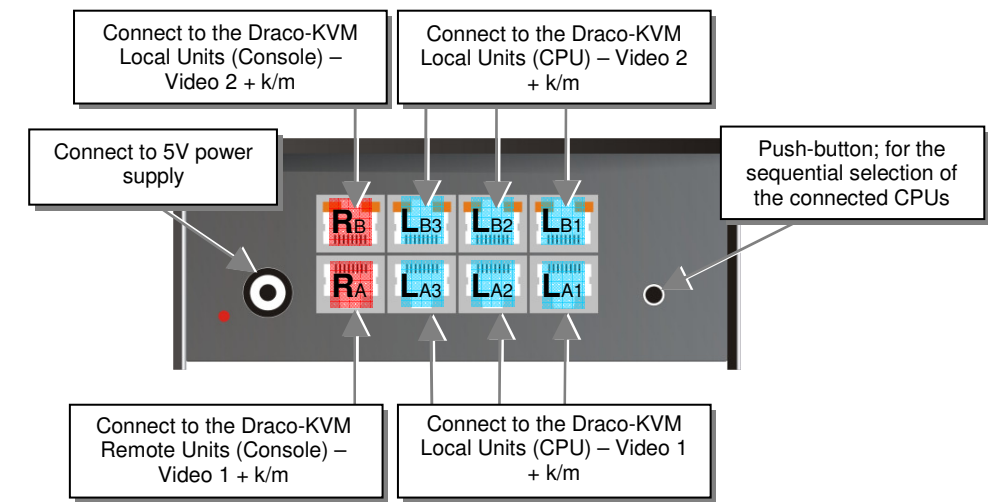

Draco-minor Switch – as Dual-Head KVM-Switch



Draco-minor Switch rear view

4 Service Setup

Normally it is necessary to make adjustments only within the initial operation.

In order to make these adjustments, you do not have to open the Draco-minor Switch. All settings can be made from the outside using the Operating Mode Selector (DIP switch).

! By pre-selecting a new operating mode the allocation of in- and outputs may be changed. Thereby it is possible to interconnect two transmitters. Damage cannot be excluded.

For the selection of a new operating mode:

1. Switch off the Draco-minor Switch.
2. Select a new operating mode according to following table.

! By pre-selecting a new operating mode the allocation of in- and outputs may be changed. Thereby it is possible to interconnect two transmitters. Damage cannot be excluded.

3. Power up the device.

4.1.1 Operating Mode Pre-selection

Operating Mode Switch

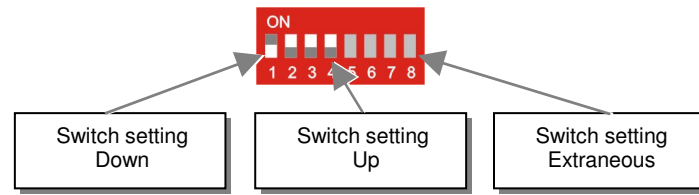

Operating Mode Switch

Multiplex- Repeater: The signal(s) coming from the Local Unit is (are) straightened (and distributed) and extended over further 140m.

 An incoming DVI (+audio) signal is distributed and extended on up to 7 outputs.	 An incoming DVI (+audio) signal is distributed and extended on up to 6 outputs.	 An incoming DVI (+audio) signal is distributed and extended on up to 5 outputs.
---	---	---

Crosspoint Switch: Every port can be either an input (to a Local Unit) or an output (to a Remote Unit). Each connection input/output is possible.

 1x IN / 7x OUT The signals of one source can be switched up to 7 displays.	 2x IN / 6x OUT The signals of two source can be switched up to 6 displays.	 3x IN / 5x OUT The signals of 3 sources can be switched up to 5 displays.
 4x IN / 4x OUT The signals of 4 sources can be switched up to 4 displays.	 5x IN / 3x OUT The signals of 5 sources can be switched up to 3 displays.	 6x IN / 2x OUT The signals of 6 sources can be switched up to 2 displays.
 7x IN / 1x OUT The signals of 7 sources can be switched up to one display.		

KVM- Switch 1/7 Single-Head : Up to 7 CPUs can be operated from one console (up to 49 with cascaded application).

KVM- Switch 1/3 Dual-Head : Up to 3 CPUs with Dual-Head graphic card can be operated from one console (up to 9 with cascaded application).

Standard operating mode

Reset the Draco-minor Switch to default settings (Factory Reset):

1. switch power off
2. set the DIP- switch
3. switch power on, the device is resetting
4. switch power off

5. set the DIP- switch back
6. switch power on - done

Operating Mode after Reset/ Power ON: After reset the respective DEFAULT-mode is selected.

Operating Mode after Reset/ Power ON: After reset the previous mode before reset or power off is selected.

Master: In a cascaded application as KVM- switch the device is 'Master' – i.e. it is on highest level within the tree structure, seen from the Remote Unit.

Slave: In a cascaded application as KVM- switch the device is 'Slave' – i.e. it is on second level within the tree structure, seen from the Remote Unit.

5 Diagnostic

Each Draco-minor Switch is fitted with two indicator LEDs: *Power and Link Status*: The *Power* LED is next to the Power socket. The *Link Status* LEDs are at the upper CATx- connectors in the left and right upper corner. The LEDs in the left corners show the status for the lower CATx- connectors, the right LEDs for the upper CATx- connectors.

The location of the LEDs is shown below:

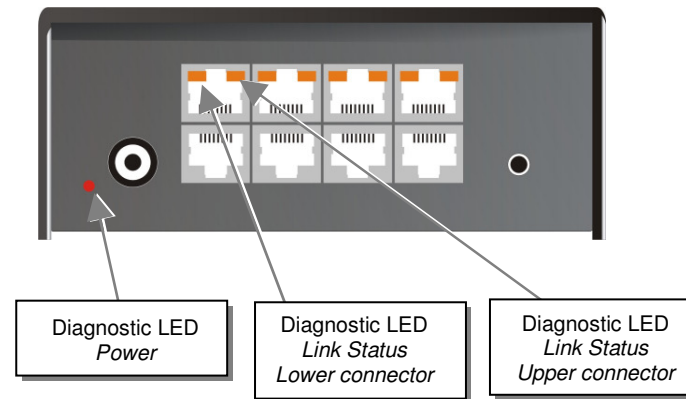

Diagnostic- LEDs at Draco-minor Switch for CATx

LED	Appearance	Diagnostics
Power LED (Red LED)	Off On	Device not ready Device ready
Link Status (Orange LED)	Off blinking On	No transmission over the CATx- cable active connection (only type KVM- Switch) Connection OK

6 Troubleshooting

6.1.1 Monitor

There isn't a picture.

Check the power supply connection at the Local and Remote Unit. Is the *Power* LED at the Local and Remote Unit illuminated? If not, the internal power supply may be damaged or there may be an internal error.

Check that the interconnection cable is connected at the Local Unit and the Remote Unit. Is the *Link Status* LED illuminated? If not, there may be a problem with the interconnection cable:

Are there errors through data transmission over CATx- cable (cable too long, too high attenuation or too much EMI interferences)? Is the *Data Error* LED illuminated or blinking? If yes, check cable length and environment.

Video Okay LED is dark: CPU does not provide a video signal – Check settings of the graphic card. Try out, connecting a monitor to the local output, to see, whether there is a signal or not.

„Juddering“ pictures at video presentations

Due to the high monitor resolutions the data volume that can be transferred exceeds the available bandwidth by far, so the data must be reduced. For this a RLE compression algorithm is used at first. If the necessary compression factor is not reached, not all pictures of the graphic card are transferred (frame dropping). That is the reason why the video presentation may begin to „judder“.

Hint: Use a lower resolution, which is a little larger than the resolution of the stored film material. If the monitor has a higher resolution, then this can take over the scaling of the video data. For the image quality it is irrelevant whether the scaling is done via the CPU or via the monitor.

Hint: Set the colour depth to 16 bits. Usually the human eye is not able to differentiate between so many different colours with moving pictures. A reduction on 16 bits makes the data volume that has to be transferred smaller without loss of image quality.

6.1.2 USB- Keyboard/ Mouse

Your USB-keyboard/USB-mouse does not work

Although we tried to design the devices as transparent as possible, we can't ensure that all devices are running. Please check the list of supported devices.

Your USB- Mouse makes "jerky leaps"

Due to the high monitor resolutions the data volume that can be transferred exceeds the available bandwidth by far, so the data must be reduced. For this a RLE compression algorithm is used at first. If the necessary compression factor is not reached, not all pictures of the graphic card are transferred (frame dropping). Thus the mouse may make jerky leaps.

Hint: Use a lower resolution or a background which can be compressed better: Please avoid photo-backgrounds or colour gradient – single-coloured backgrounds are optimal and permit highest possible compression rates => highest frame rates.

Your USB- Mouse moves like on a "rubber band"

This problem consists of several one-time jobs, which lead to a whole time delay between mouse movement and display on the screen. After our measurements time delays of more than 100 ms are bothering.

The total delay consists of (numerical data are approx. values):

- 5 ms mouse movement/ transmission to the CPU
- 25 – 40 ms processing time in the CPU, until data change at the graphic output appears
- 15 – 50 ms assumption of the graphic data into the extender-system and transmission to remote unit
- 15 – 100 ms processing time in the screen until data are indicated

The majority of the resulting response times between 60 and 200 ms are not a consequence of the extender-system. However, our studies show that already a step from 80ms to 110ms that can take place by inserting an extender-system is bothering.

Hint: Use a display with a shorter response time (please note: this time does not have to agree under any circumstances with the response time indicated by the manufacturer, which only means how quickly two successive pictures can be displayed, not however, how long it lasts until a signal of the input interface needs to the screen). Use a lower resolution or a background which can be compressed better: Please avoid photo-backgrounds or colour gradient – single-coloured backgrounds are optimal and permit highest possible compression rates.