

Welcome to the VTO2/VRO2 V6.00 KVM-Extender Family!

Thank you for purchasing a VTO2/VRO2 V6.00 KVM-Extender model. We appreciate your business, and we think you'll appreciate the many ways that your enhanced keyboard/video/mouse system will save you money, time, and effort.

That's because our VTO2/VRO2 V6.00 KVM-Extender not only allows you to remotely locate a console (Monitor, Keyboard, Mouse + optional serial/audio devices) over great distances without any loss in signal quality (up to 1000m/3250ft) but also to do this in an EMI hazardous environment.

Wherever you have great distances: airports, roller plants, distributed data centres; or in a range of applications where you have large electromagnetic generators or loads, magnetic resonance tomographs, induction furnaces, current generators; the VTO2/VRO2 V6.00 KVM-Extender is a solution for remotely locating your console. Three different models cover a range of applications: a VGA-only extender – for when you just need a remote display screen; a KVM extender for a standard remote console – Monitor, Keyboard and Mouse; and a third unit with KVM extension and additional serial and bi-directional audio support. This device is also suitable for computers equipped with a serial mouse or touch screen.

This manual will tell you all about your new VTO2/VRO2 V6.00 KVM-Extender, including how to install, operate, and troubleshoot it. For an introduction to the Extender, see **Chapter 2**. The Extender product codes covered in this manual are:

K234-9W: KVM-Extender for VGA, PS2-Keyboard/Mouse + Serial/Audio

K235-9W: KVM-Extender for VGA, PS2-Keyboard/Mouse

K236-9W: Extender for VGA only

Copyrights and Trademarks

©2005. All rights reserved. This information may not be reproduced in any manner without the prior written consent of the manufacturer.

Information in this document is subject to change without notice and the manufacturer shall not be liable for any direct, indirect, special, incidental or consequential damages in connection with the use of this material.

All trademark and trade names mentioned in this document are acknowledged to be the property of their respective owners.

Disclaimer

While every precaution has been taken in the preparation of this manual, the manufacturer assumes no responsibility for errors or omissions. Neither does the manufacturer assume any liability for damages resulting from the use of the information contained herein. The manufacturer reserves the right to change the specifications, functions, or circuitry of the product without notice.

The manufacturer cannot accept liability for damage due to misuse of the product or due to any other circumstances outside the manufacturer's control (whether environmental or installation related). The manufacturer shall not be responsible for any loss, damage, or injury arising directly, indirectly, or consequently from the use of this product.

Cautions and Notes

The following symbols are used in this guide:



CAUTION. This indicates an important operating instruction that should be followed to avoid any potential damage to hardware or property, loss of data, or personal injury.



NOTE. This indicates important information to help you make the best use of this product.

EUROPEAN UNION DECLARATION OF CONFORMITY

This is to certify that, when installed and used according to the instructions in this manual, together with the specified cables and the maximum cable length <3m, the Units:

K234-9W
K235-9W
K236-9W

are shielded against the generation of radio interferences in accordance with the application of Council Directive 89/336/EEC as well as these standards:

EN 55022:	1999	Class A
EN 55024:	1999	
IEC 61000-4-2:	2001	
IEC 61000-4-3:	2001	
IEC 61000-4-4:	2001	
EN 61000-3-2	2001	
EN 61000-3-3	2002	

The device was tested in a typical configuration with PC.



Oberteuringen, Wednesday, October 11th, 2006

The management

A handwritten signature in black ink that reads "Peter Prigel". The signature is written in a cursive style with a large, looped 'P' and 'r'.

This equipment has been found to comply with the limits for a Class A digital device, pursuant to Part 15 of the FCC Rules. These limits are designed to provide reasonable protection against harmful interference when the equipment is operated in a commercial environment. This equipment generates, uses, and can radiate radio frequency energy and, if not installed and used in accordance with the instruction manual, may cause harmful interference to radio communications. Operation of this equipment in a residential area is likely to cause harmful interference in which case the user will be required to correct the interference at his own expense.

Safety Precautions and Installation Guidelines

To ensure reliable and safe long-term operation, please note the following installation guidelines:

- Only use in dry, indoor environments.
- The Remote unit, Local unit and any power supplies can get warm. Do not locate them in an enclosed space without any airflow.
- Do not place a power supply directly on top of a unit.
- Do not obstruct a unit's ventilation holes.



To safeguard against personal injury and avoid possible damage to equipment or property, please observe the following:

- **Only use power supplies originally supplied with the product or manufacturer-approved replacements. Do not attempt to dismantle or repair any power supply. Do not use a power supply if it appears to be defective or has a damaged case.**
- **Connect all power supplies to grounded outlets. In each case, ensure that the ground connection is maintained from the outlet socket through to the power supply's AC power input.**
- **Do not attempt to modify or repair this product**

Contents

1. Quick Setup	6
2. Overview	7
2.1 Introduction	7
2.2 Glossary	7
2.3 Features	9
2.4 Product Range	10
2.5 Compatibility	11
2.6 How to Use This Guide	12
3. Installation	13
3.1 Package Contents	13
3.2 Interconnection Cable Requirements	14
3.3 System Setup	15
3.4 Diagnostic and Adjustments	21
4. Adjustments	25
4.1 Jumper Location in the Local Unit	26
4.2 Jumper Location in the Remote Unit	27
4.3 Customization	27
5. Monitor Setup	30
5.1 TFT Monitors	32
5.2 Hints for Pixel Clock and Pixel Phase	33
5.3 Manual Adjustment of Video Signals	34
6. Troubleshooting	35
Appendix A: Example Applications	36
Appendix B: 19" Rack Mount Options	38
Appendix C: Audio/Serial Upgrade	40
Appendix D: Technical Support	42
Appendix E: Specifications	43
Appendix I: Connectors	45

1. Quick Setup

This section briefly describes how to install your KVM extender system and optimise the video signals. Unless you are an experienced user, we recommend that you follow the full procedures described in the rest of this manual.

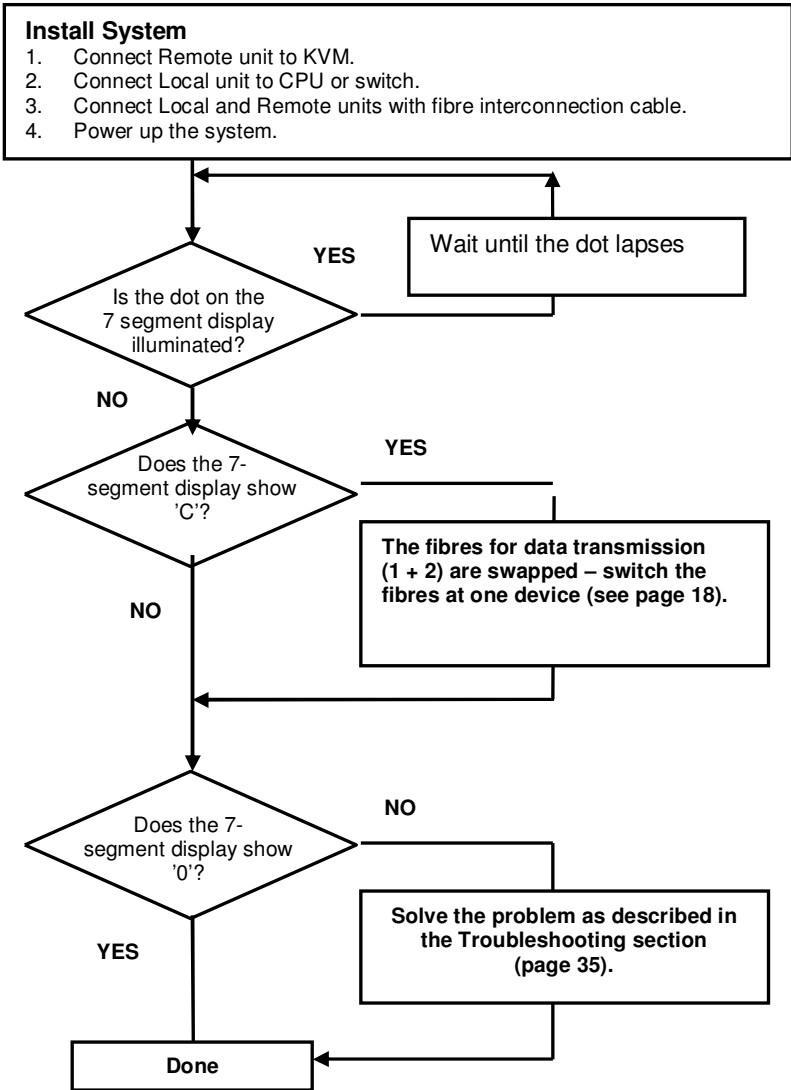

2. Overview

2.1 Introduction

With a fibre KVM Extender you can dramatically increase the maximum distance between a CPU and its Console – the keyboard/mouse and monitor (+ serial/audio devices). In addition, they are essential for installations in hazardous EMI environments. Normal keyboard/mouse/monitor extender cables (and Extenders using regular cables) have lower extension capabilities and EMI interference may further reduce the maximum distance and reliability. The VTO2/VRO2 fibre optical KVM Extender System has none of these limitations. Locate your CPU in a secure cabinet or data centre and access it remotely from a distance of up to 1000m.

A basic KVM extension system comprises a *Local* unit (transmitter) and a *Remote* unit (receiver). The Local unit connects directly to the computer (or a KVM switch system) using the supplied cable(s). The user *console* (keyboard, mouse and monitor) attaches to the Remote unit. The Remote and Local units communicate video and data information along the interconnecting cable. Local units offer dual access, allowing the connection of a second user console close to the computer. With the optional upgrade kit, you can also use the units to communicate stereo audio and serial port signals.

2.2 Glossary

The following terms are used in this guide:

Multimode	Any multimode 3/5-fibre cable 50/125 μ or 62.5/125 μ (depending on device type)
PSU	The desktop power supply connected to the Local/Remote unit.
KVM	Keyboard, Video (monitor) and Mouse.
Console	A keyboard, monitor, and mouse, plus optional serial/audio devices.
Dual Access	A system allowing connection of Local and Remote user consoles.
RGB	Video signal, consisting of R (red) G (green) and B (blue) signals. The signals have a level of 0.7Vpp. The Green-Signal also carries the (composite) synchronisation signals.
RGBS	Video signal, consisting of R (red) G (green) and B (blue) signals and the additional (composite) SYNC signal. All signals have 0.7Vpp.
VGA (also called RGBHV)	Video signal, consisting of R (red) G (green) and B (blue) signals and the additional horizontal/vertical synchronisation signals. The colour signals have a level of 0.7Vpp, the synchronisation TTL (5Volts).

VTO2/VRO2 KVM-Extender System

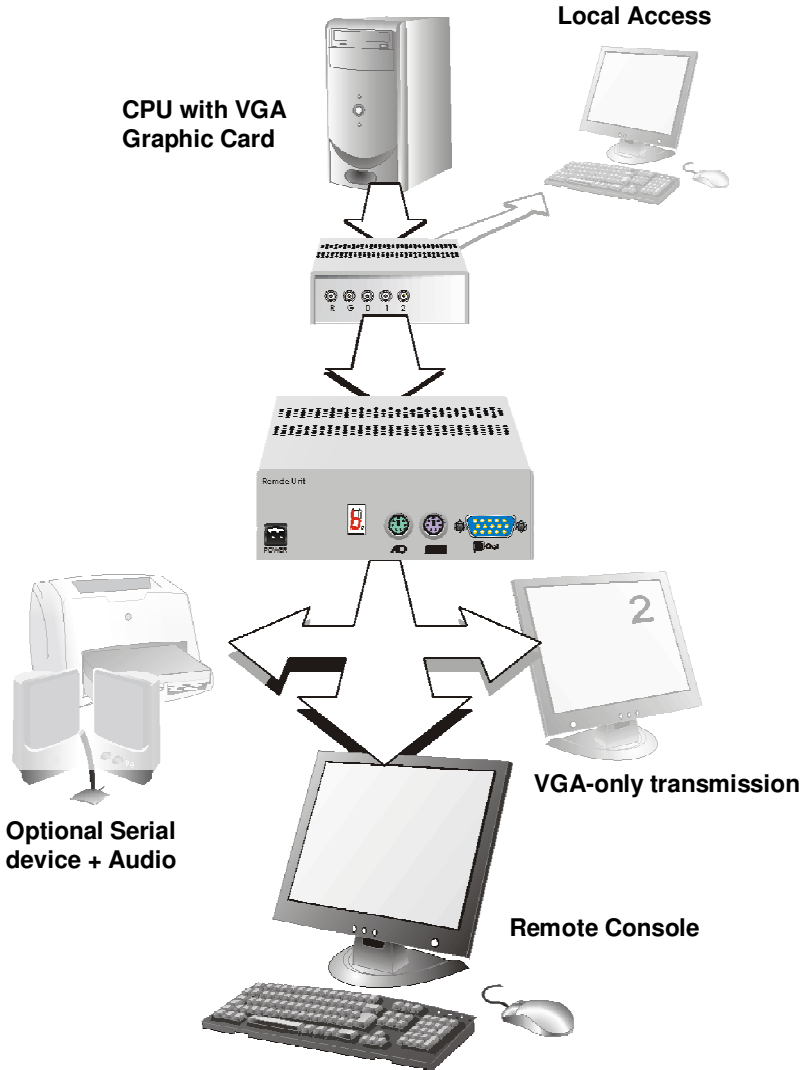

2.3 Features

The VTO2/VRO2 V6.00 KVM-Extenders offer the following features:

- Support for VGA Graphic Cards (all models).
- Support for PS2-Keyboard and PS2-Mouse. Intelligent PS/2 keyboard and mouse emulation ensures PCs do not lock up and allows peripherals to be hot-plugged (K235-9W and K234-9W only).
- Transparent serial port (on K234-9W only) enables any serial device to be extended (up to 19.2K Baud). The serial port may be used to extend one device (requiring handshaking lines) or up to three simple serial devices (no handshaking).
- Bi-directional stereo audio (16-bit digitised) support (K234-9W only) enables high-quality, low-noise, audio extension.
- Maximum Resolution:
VGA: 1280x1024@75Hz.
- Status indicator LED on each device.
- 7-Segment diagnostic display on Remote Unit aids troubleshooting.
- Small footprint chassis.
- Rack mount options available.
- CPU KVM-cable (1.8m) + universal PSU included.

2.4 Product Range

There are three products in the range and various mounting options:

VTO2/VRO2 - Extender

K234-9W	KVM-Extender for VGA, PS2-Keyboard/Mouse Serial/Audio
---------	--

K235-9W	KVM-Extender for VGA, PS2-Keyboard/Mouse
---------	--

K236-9W	Extender for VGA only
---------	-----------------------

Upgrade Kits

437-1G	19" 1U Rack Mount Kit (RMK) to mount up to 3 devices in a 1U rack space
--------	--

285-2K	Mounting brackets to mount by screws
--------	--------------------------------------

286-2K	Mounting brackets to mount by snap-on
--------	---------------------------------------

235-3V	Optical fibre pigtail (3 pieces), each 1m (3 ft) including ST/ST coupler (3 pieces) device K236-9W only
--------	--

235-5V	Optical fibre pigtail (5 pieces), each 1m (3 ft) including ST/ST coupler (5 pieces) devices K234-9W or K235-9W
--------	---

2.5 Compatibility

Interface Compatibility

- **VGA (also called RGBHV):** Video signal, consisting of R (red) G (green) and B (blue) signals and the additional horizontal/vertical synchronisation signals. The colour signals have a level of 0.7Vpp, the synchronisation TTL (5Volts).
- **RGB:** Video signal, consisting of R (red) G (green) and B (blue) signals. The signals have a level of 0.7Vpp. The Green-Signal also carries the (composite) synchronisation signals.
- **PS/2 Keyboard:** Compatible with all standard keyboards. Certain keyboards with enhanced features may also be supported with custom firmware.
- **PS/2 Mouse:** Compatible with all standard 2-button, 3-button and wheel mice.
- **Audio:** Input and output are line-level. Amplified speakers are required. A microphone may be directly connected to the Remote unit (optional pre-amplification).
- **Serial:** Transparent up to 19.2K Baud. The following serial signals are extended: TX, RX, RTS, CTS, DTR, DSR. In rare cases, a wiring adaptor may be required to transfer RI and DCD.

2.6 How to Use This Guide

This guide describes the installation and configuration of the VTO2/VRO2 V6.00 KVM-Extender Series. Although the connection and operation of the system is relatively straightforward, you should consider the following before getting started:

Connection & Compatibility

If you have purchased a *VTO2/VRO2 V6.00 KVM-Extender Kit*, this will contain all the cables required to connect the Local unit to your PC or KVM switch. The Remote console (keyboard, monitor and mouse) and any audio and serial equipment connect directly to the Remote unit.

For information about connection and installation, see *Installation*, page 13.

Graphic Source (RGB or VGA)

The device can transmit RGB signals as well as VGA. In addition, it is able to convert from VGA to RGB as well as from RGB to VGA.

Factory setting: **VGA** (see page 27).

Fibre Cable (50µ or 62,5µ)

The VTO2/VRO2 V6.00 KVM-Extender can be used with 50µ or 62,5µ fibre cable. The transmission power must be adjusted to the type of cable. You need not to modify the setting, if at least one of the following two circumstances become true: 1st the cable type is 50µ, 2nd the cable length exceeds 100m. (see also page 27)

Automatic Gain Control (AGC)

In some applications (e.g. RGB Signals) it may be necessary to switch off the Automatic Gain Control.

Factory setting: Automatic Gain Control **ON** (see page 27)

Compatibility

The devices in version 6.00 are NOT compatible with previous versions.

3. Installation

For first-time users, we recommend that you carry out a test placement, confined to a single room, before commencing full installation. This will allow you to identify and solve any cabling problems, and experiment with the KVM extender system more conveniently.

3.1 Package Contents

You should receive the following items in your extender package:

- VTO2/VRO2 V6.00 KVM-Extender Local Unit
- VTO2/VRO2 V6.00 KVM-Extender Remote Unit
- VGA CPU cable, ZIP type 1,8m (HD15 male / HD15 female, 2 x PS2 male / PS2 male)
Models K234-9W and K235-9W
- VGA CPU-cable 1,8m (HD15 male / HD15 female)
Model K236-9W only
- Audio CPU-cable 1,8m (3,5mm Stereo Jack / 3,5mm Stereo Jack)
Model K234-9W only
- Serial CPU-cable 1,8m (DB9 female / DB9 male)
Model K234-9W only
- 2 x 6V DC universal PSU
- 2 x power cord
- Manual (Quick Setup)
-

If anything is missing, please contact Technical Support (see **Appendix D – Technical Support**).

3.2 Interconnection Cable Requirements

CPU/Local Unit Connections

To connect the Local unit to your graphic source you will need:

- **VGA (K236-9W):** Connect the supplied VGA CPU-cable 1,8m (HD15 male / HD15 female) to the CPU (KVM - Switch, etc.). Please ensure that the connection is tension-free.
- **VGA, Keyboard, Mouse (K234-9W + K235-9W):** Connect the supplied VGA CPU cable, ZIP type 1,8m (HD15 male / HD15 female, 2x PS2 male / PS2 male) to the CPU (or KVM Switch). Please ensure that the connection is tension-free.

Power Supplies

Connect the supplied 6V/DC power supplies to the *Plug* terminals on the rear of both the Local and Remote units.

Local Unit/Remote Unit Connection

To connect the Local and Remote units you will need:

- **Multimode Fibre Cable:** 3 Fibres 50µm or 62.5µm – ST-plugs. (K236-9W)

Multimode Fibre Cable: 5 Fibres 50µm or 62.5µm – ST-plugs. (K234-9W+K235-9W)



If you want to use the devices with fibres 62,5µ AND the cable length falls short of 100m, it might be necessary, to reduce the optical budget. For this purpose, optical fibre pigtailed are available. (see also page 10).

3.3 System Setup

To install your VTO2/VRO2 V6.00 KVM-Extender system:

1. Switch off all devices.
2. Connect your keyboard, monitor, mouse, audio device and serial device to the Remote unit (depending on type of device). Ensure that you attach the keyboard and mouse connectors to the correct ports. The keyboard connector is purple; the mouse connector is green.
3. Connect the CPU to the Local Unit, using the supplied CPU cable. Ensure that you attach the keyboard and mouse connectors to the correct ports. The keyboard connector is purple; the mouse connector is green.
4. Connect the 6V power supplies to the Local and Remote units.



Only use the power supply originally supplied with this equipment or a manufacturer-approved replacement.

5. For a dual access system, connect the keyboard, mouse and monitor for the Local console to the appropriate ports on the Local unit. The ports may also be used to feed into a KVM switch.
6. Connect the Interconnection cable (Multimode Fibre Cable) from the Remote unit to the Local unit. Ensure that you attach the fibre connectors to the correct ports. R goes to R, G to G, B to B, 1 to 1 and 2 to 2.
7. Power up the system.

VTO2/VRO2 V.6.00 –5 STRAND KVM-EXTENDER

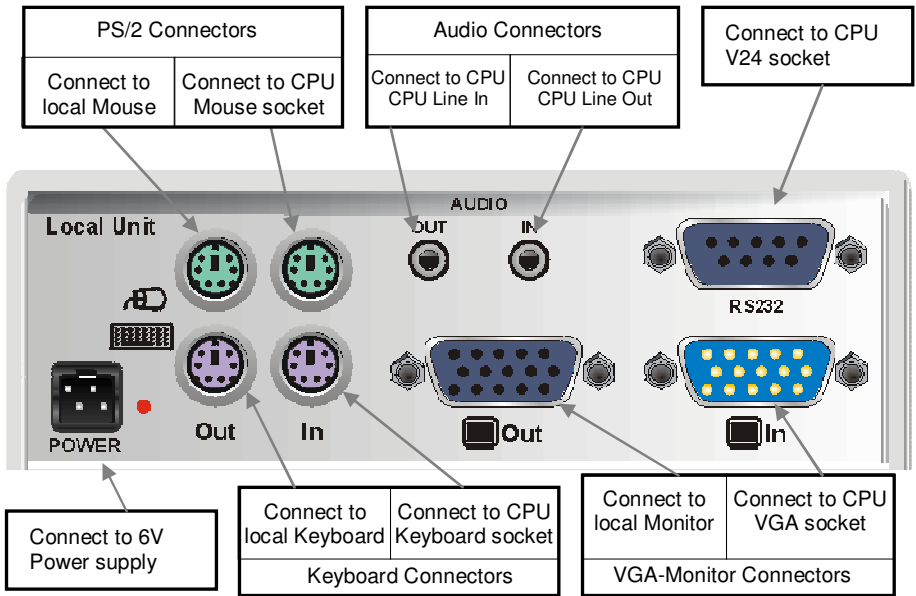

VTO2/VRO2 V6.00 KVM-Extender Type K234-9W Local Unit

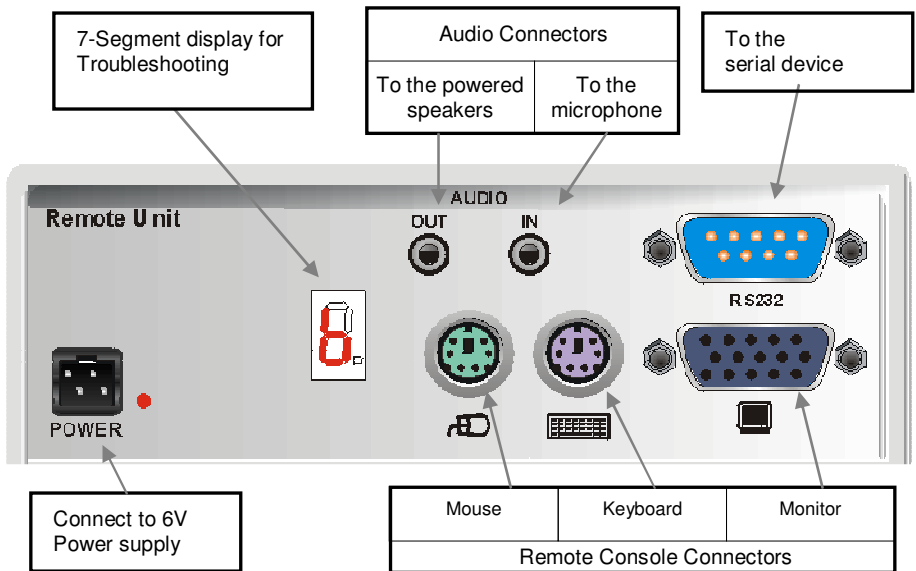

VTO2/VRO2 V6.00 KVM-Extender Type K234-9W Remote Unit

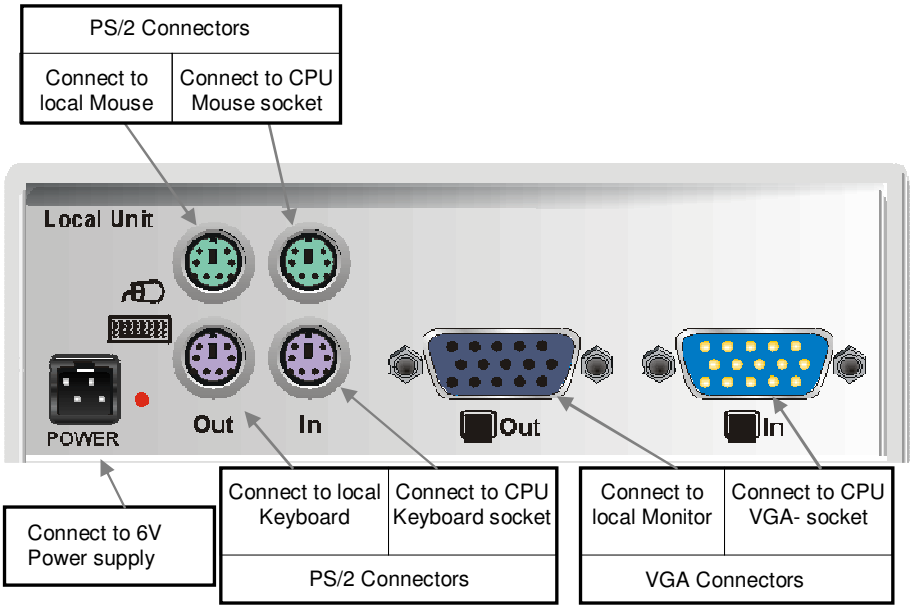

VTO2/VRO2 V6.00 KVM-Extender Type K235-9W Local Unit

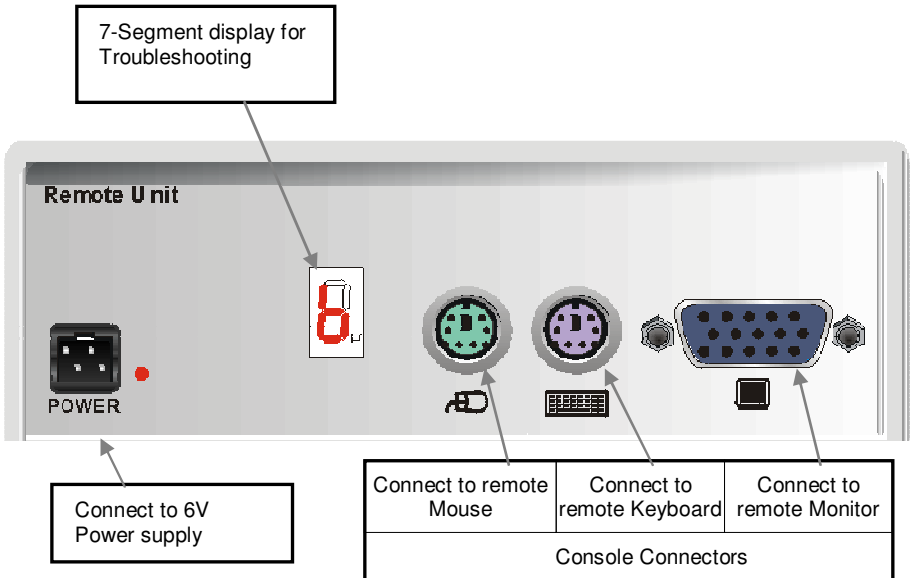

VTO2/VRO2 V6.00 KVM-Extender Type K235-9W Remote Unit

VTO2/VRO2 V.6.00 -5 STRAND KVM-EXTENDER

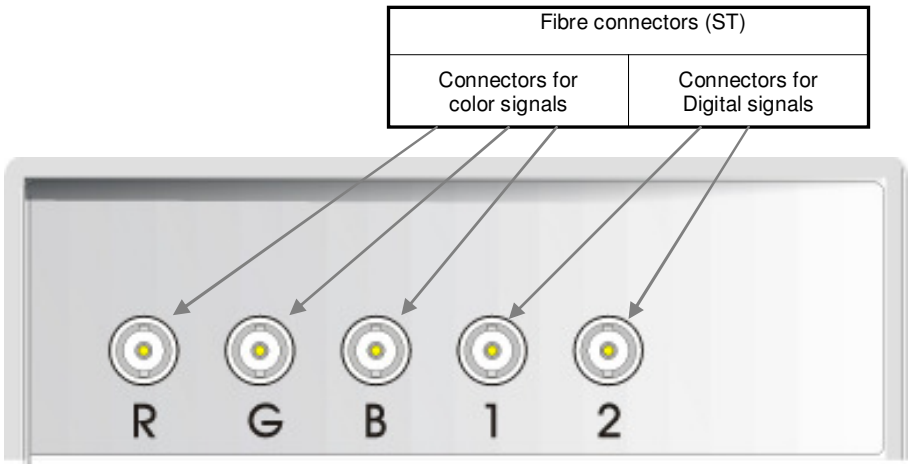

VTO2/VRO2 V6.00 KVM-Extender Type K234-9W + K235-9W Local Unit

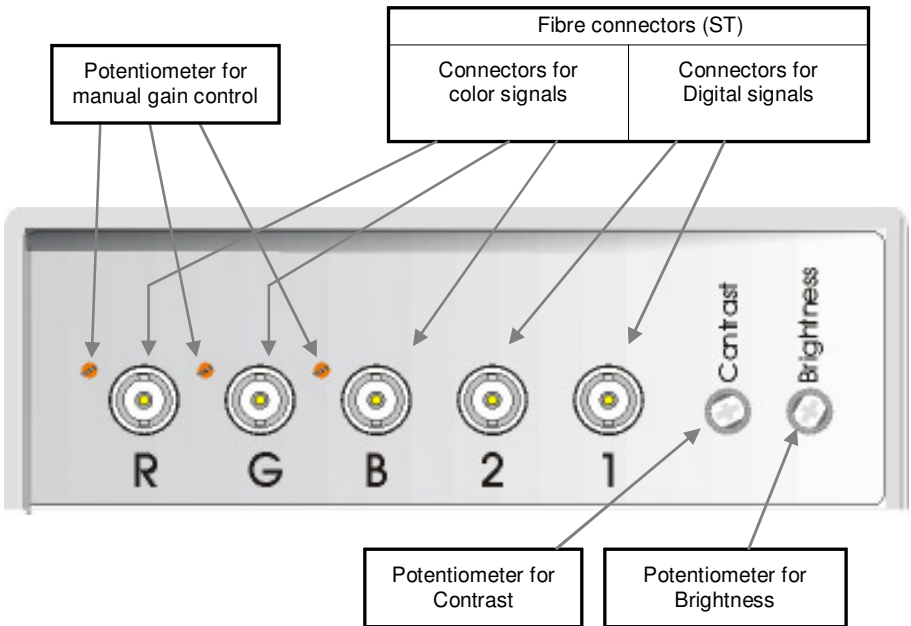

VTO2/VRO2 V6.00 KVM-Extender Type K234-9W + K235-9W Remote Unit

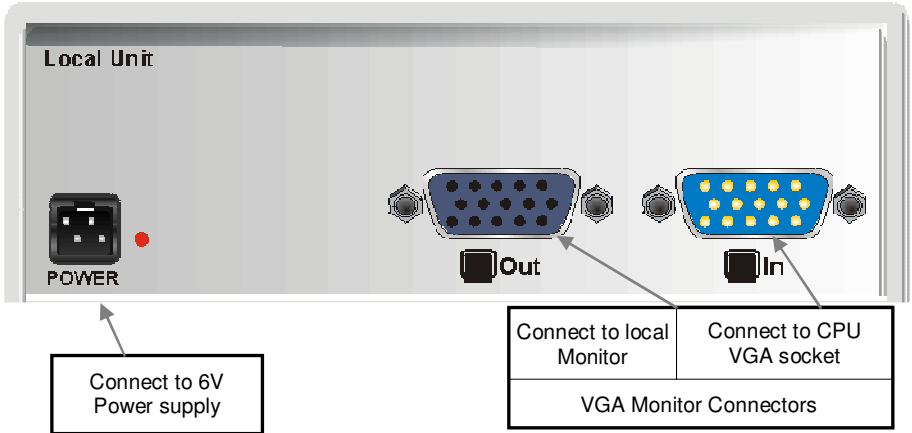

VTO2/VRO2 V6.00 KVM-Extender Type K236-9W Local Unit

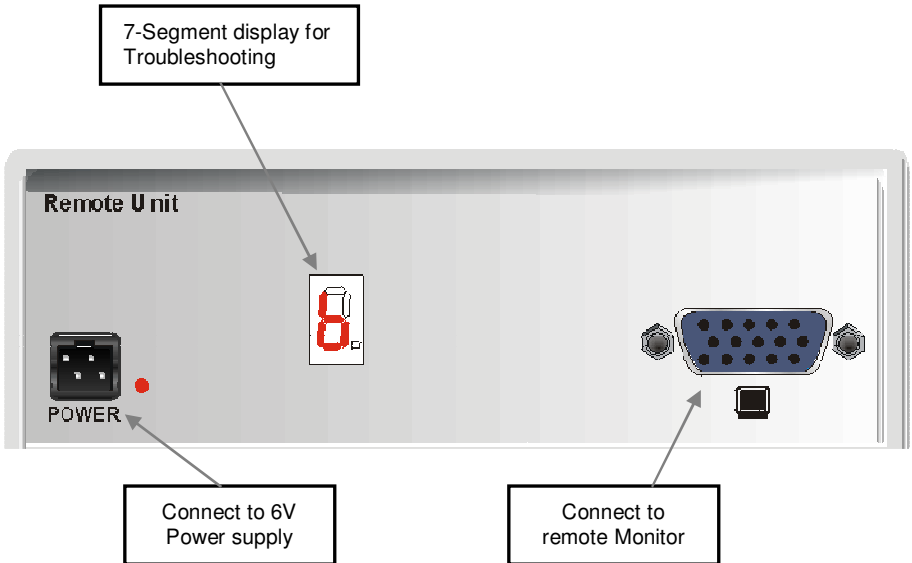

VTO2/VRO2 V6.00 KVM-Extender Type K236-9W Remote Unit

VTO2/VRO2 V.6.00 –5 STRAND KVM-EXTENDER

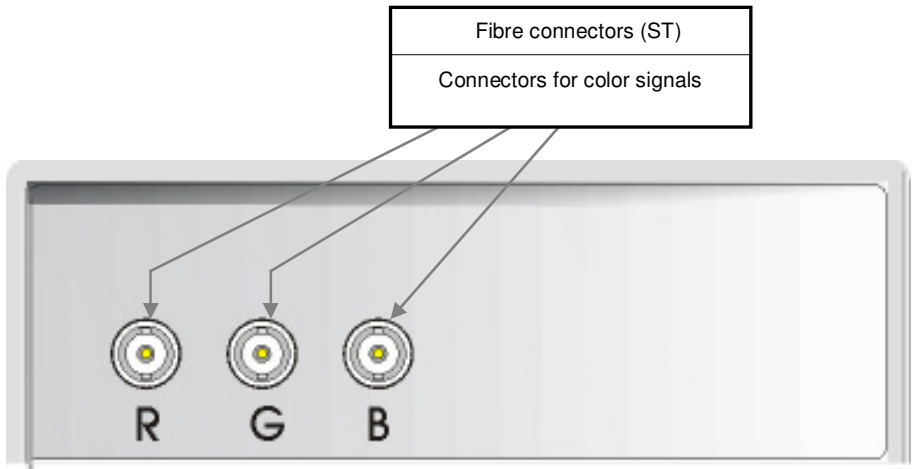

VTO2/VRO2 V6.00 KVM-Extender Type K236-9W Local Unit

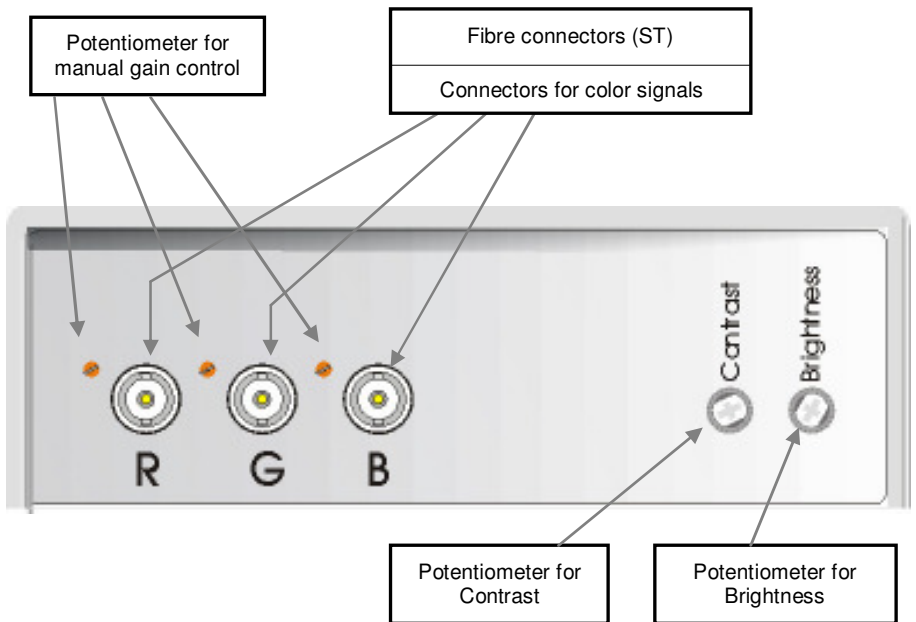

VTO2/VRO2 V6.00 KVM-Extender Type K236-9W Remote Unit

3.4 Diagnostic and Adjustments

Each VTO2/VRO2 V6.00 KVM-Extender is fitted with an indicator LED *Device Ready* and a 7-Segment display for enhanced troubleshooting: The *Device Ready* LEDs are next to the power sockets. The 7-Segment display is next to the power socket of the remote unit.

On each VTO2/VRO2 V6.00 KVM-Extender you can adjust Brightness and Contrast manually. In addition, each colour can be adjusted manually (only with automatic gain control – AGC = OFF). The potentiometers to adjust Brightness and Contrast are to the right of the fibre connectors on the Remote unit. The 7- Segment display is next to the Power socket of the Remote unit.

The location of the LEDs is shown below:

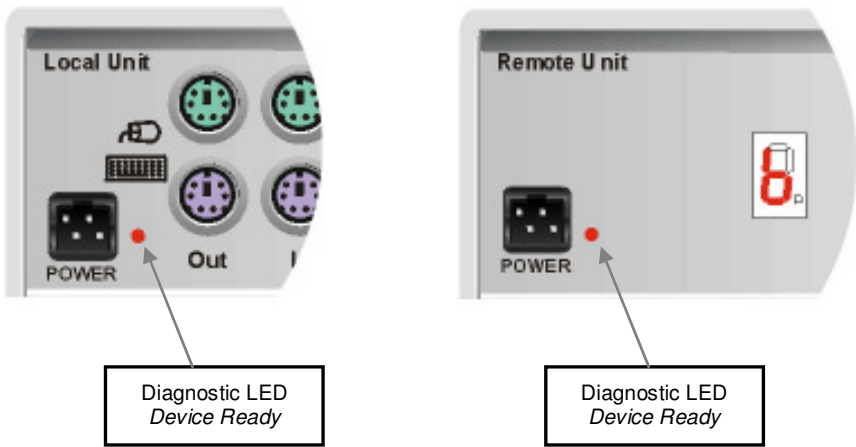

Diagnostic LEDs on VTO2/VRO2 Extender

<i>LED</i>	<i>Appearance</i>	<i>Diagnostics</i>
Device Ready (Red LED)	Off	Device not ready
	On	Device ready

The location of the 7- Segment display is shown below:

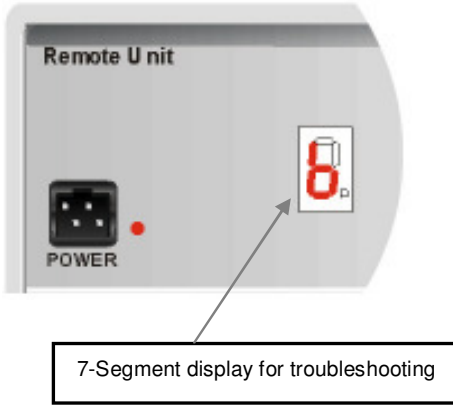

7-Segment display on VTO2/VRO2 Extender

<i>7-Segment display</i>	<i>Diagnostics</i>	<i>Possible cause of fault</i>
0	Only in mode “AGC-ON” NO error	NO error detectable
.	Only in mode “AGC-ON” illuminated	NO error detectable: Processor adjusts color amplifying (AGC)
b	Blank-pulse is missing	Problem with the GREEN fibre
C	Data interface (receiving) deranged	Problem with the 1-Fibre Problem with the Local Unit 1-Fibre and 2-Fibre swapped
F	Contrast is adjusted too high	The gain of the contrast potentiometer is adjusted too high. Automatic Gain Control (AGC) is no longer possible. Please re- adjust to lower gain.
H	HSYNC signal is missing	Problem with the GREEN fibre Problem with the CPU cables Wrong jumper setting in the Local unit
U	VSYSNC signal is missing	Problem with the BLUE fibre Problem with the CPU cables Wrong jumper setting in the local unit

The location of potentiometers for brightness/contrast control is shown below:

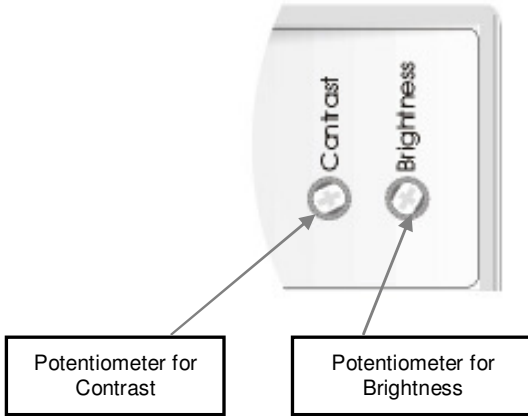

Brightness/Contrast controls on VTO2/VRO2 – Extender

On each VTO2/VRO2 V6.00 KVM-Extender you can adjust Brightness and Contrast manually. You'll find the potentiometers to the right hand of the fibre connectors on the Remote unit. Please use these potentiometers for adjustment of all colours simultaneously.



If the gain of the contrast potentiometer is adjusted too high, Automatic Gain Control (AGC) is no longer possible. Please readjust to lower gain until the 'F' on the 7-Segment display lapses.

The location of potentiometers for manual gain control is shown below:

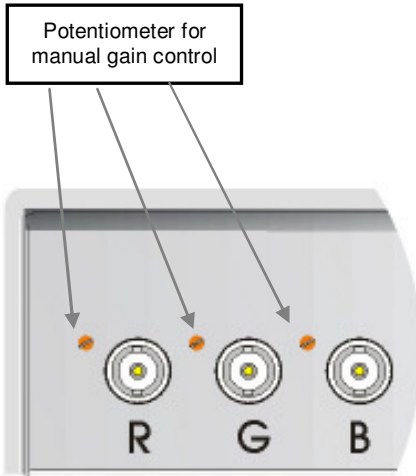

Potentiometer for manual gain control on VTO2/VRO2 – Extender

On the front panel of the Remote unit there are potentiometers to adjust the gain of each colour signal. In the mode 'With AGC', these potentiometers have no function. In the mode 'Without AGC' you can adjust the factory setting for the gain of each single colour. This may be necessary if there is a different attenuation between the three lines. This could result in chromatic aberrations on screen.



Use the AGC Mode 'Automatic Gain Control = OFF' only if there are problems that you can't solve with 'AGC = ON'.

In mode 'AGC = ON' the gain of each colour signal is fixed, since all have the same white level (0.7Vpp). The individual color potentiometers do not function. Use the brightness and contrast controls to achieve the best screen display.

Use mode 'AGC = OFF' if you see chromatic aberrations on the screen. Each colour has to be adjusted by using the appropriate potentiometer. You can adjust by visual comparison or use an oscilloscope to get the best results. Brightness and contrast control allow further control of the screen display. Please do not select this mode unless you have problems with your display (see also above).

4. Adjustments

For most applications, you shouldn't need not to make any adjustments to set up your VTO2/VRO2 V6.00 KVM-Extender.

For some applications, you may need to open the Local Unit and/or the Remote Unit. Unscrew the Philips-type screws at both sides of the device. Unscrew the UNC type screws at both sides of the monitor connectors. Carefully displace the lower and upper shells of the case.



Model K234-9W carries a Serial/Audio daughter board connected through a flat cable to the main board. Please remove the upper shell carefully to avoid damaging the flat cable.

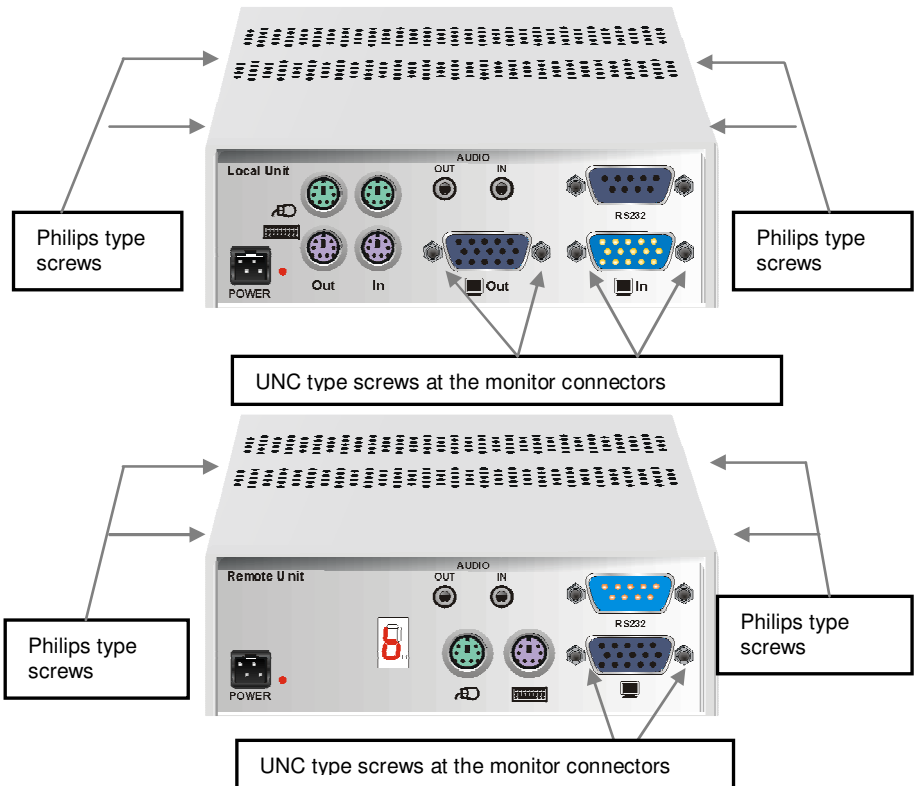

4.1 Jumper Location in the Local Unit

After unscrewing and opening the upper shell, please place the device in this orientation: with the fibre connectors to the left and the electrical connectors to the right.

The main PCB then will look like this:

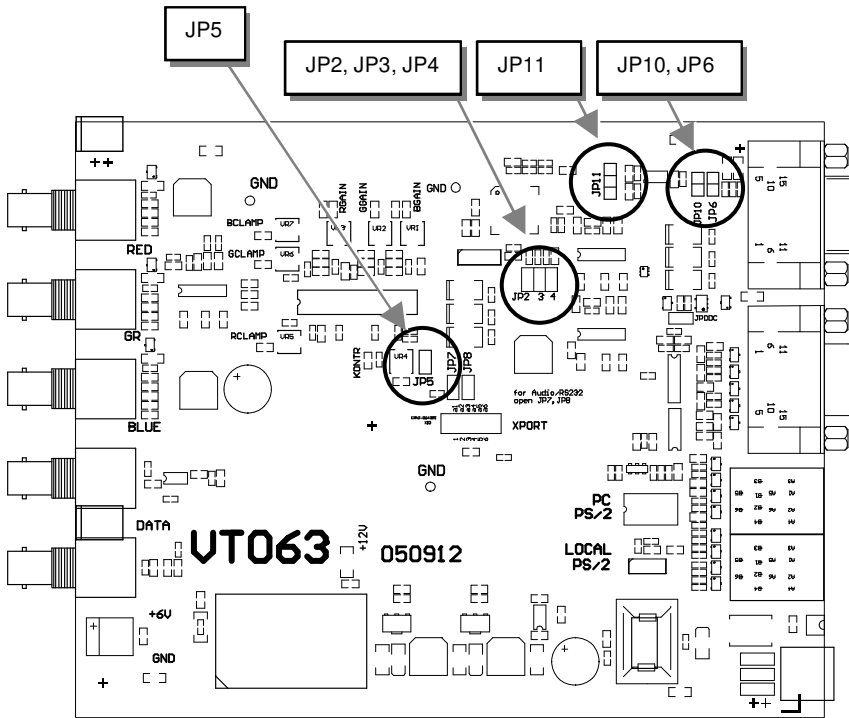

Use the diagram to locate jumpers JP2, JP3, JP4, JP5, JP6, JP10, and JP11.

4.2 Jumper Location in the Remote Unit

After unscrewing and opening the upper shell, please place the device in this orientation: with the fibre connectors to the left and the electrical connectors to the right.

The main PCB then will look like this:

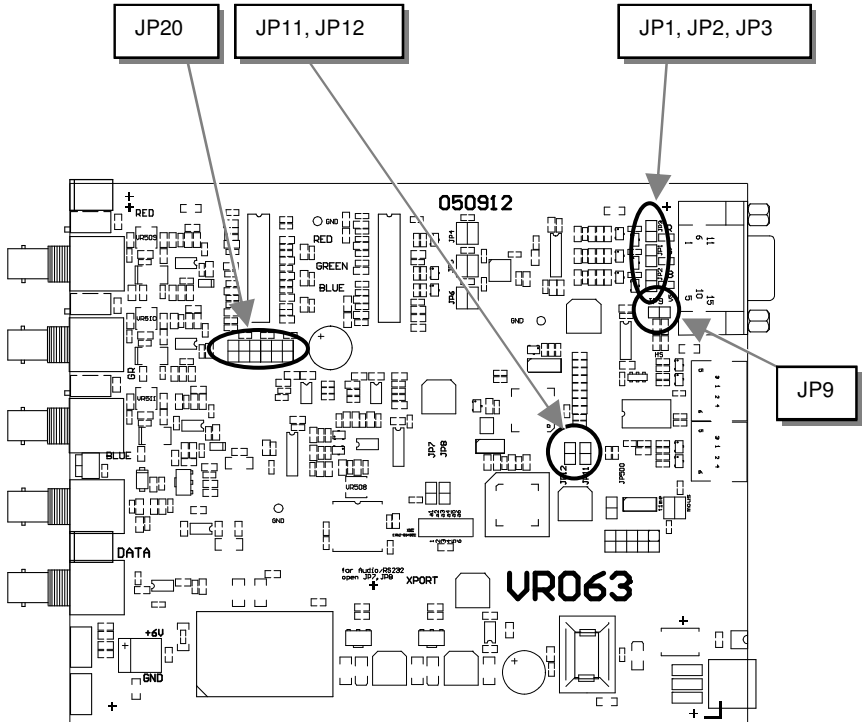

























Use the diagram to locate jumpers JP1, JP2, JP3, JP9, JP11, JP12 and JP20. Customization

You can make the following application-specific adjustments:

Changing the graphic source (RGB or VGA)

This device can transfer RGB as well as VGA signals. In addition, it is able to do a signal conversation while transferring the signals from RGB to VGA, or from VGA to RGB. Factory setting: **VGA in – VGA out**

 = open  = shorted

Local Unit Jumpers:		VGA Source VGA Monitor	VGA Source RGB Monitor	RGB Source VGA Monitor	RGB Source RGB Monitor
	JP2				
	JP6				
	JP10				
	JP11				
Pins 13&14 (HS, VS) from CPU		connected	connected	open	open
Remote Unit Jumpers					
	JP1, 2, 3				
	JP9				
	JP12				
Pins 13&14 (HS, VS) to Monitor		connected	open	connected	open
Use Remote Unit's controls?					
	Contrast	if necessary	if necessary	if necessary	if necessary
	Brightness	no	if necessary	no	if necessary

Using 62.5µ fibre cable

The VTO2/VRO2 V6.00 KVM-Extender can be used with 50µ or 62,5µ fibre cable. The transmission power must be adjusted to the type of cable. You need not to modify the setting, if at least one of the following two circumstances become true: 1st the cable type is 50µ, 2nd the cable length exceeds 100m.





If you use a 62.5µ fibre AND the cable length falls short of 100m, please connect the devices without modifications and evaluate the function! In many cases, the devices will work also with shorter cables because of other attenuating components e.g. patch panels, ...

If you recognize an instable screen picture, you need to attenuate the optical budget. To do this, so called optical fibre pigtaills are insertet at the local unit. These fibres in combination with the coupling connectors raise the optical loss to a value, where a correct function is assured. These optical fibre pigtaills you can get from your dealer for free (see also **Product Range** on page 10

Switch OFF the Automatic Gain Control (AGC)

With AGC = ON, the gain of each color signal is fixed so that all have the same white level (0,7Vpp). The potentiometers are without function. Use the brightness and contrast control to adjust the screen display.

With AGC = OFF: each color has to be adjusted by using the appropriate potentiometer. You can adjust by visual comparison or use an oscilloscope to get best results. Brightness and contrast control allow private adaptation to desired screen display. Please do not select this mode unless you have problems, such as chromatic aberration, with your display. Factory setting: Automatic Gain Control **ON**

AGC	JP3 in Local Unit	JP20 in Remote Unit
<i>ON (Factory setting)</i>		
<i>OFF</i>		

5. Monitor Setup

This schematic diagram shows the principles of data transmission through the extender system:

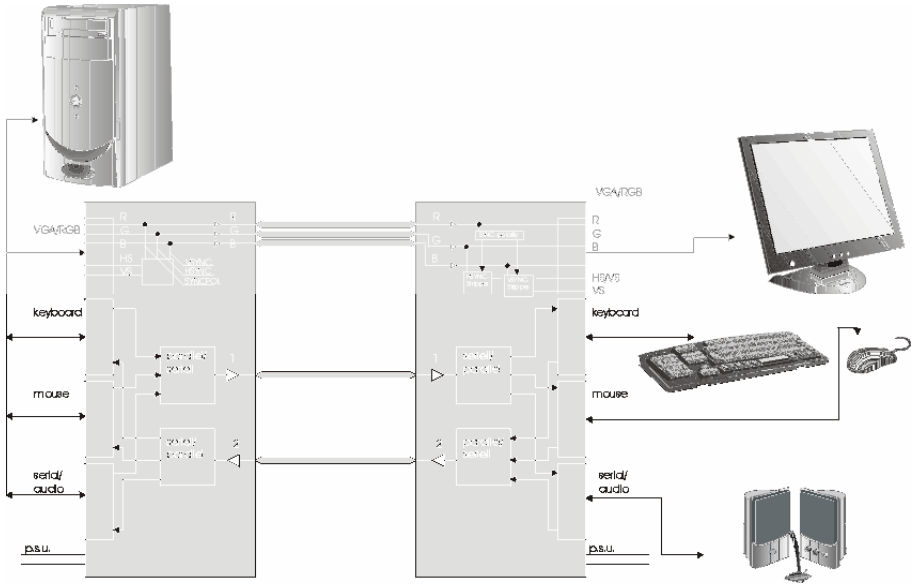

Normally you should not need to make any modifications. However, under some circumstances, you may want to customize the extenders:

Changing the Graphics

The factory setting for our devices is to transmit VGA signals to a VGA screen (VGA in/VGA out). By changing the appropriate jumper settings the units can also be used for:

- **VGA in/RGB out:** RGB monitor displaying output from a VGA graphics card
- **RGB in/RGB out:** RGB monitor displaying output from an RGB graphics card
- **RGB in/VGA out:** VGA monitor displaying output from an RGB graphics card

VGA in/RGB out

This application uses the extender as a VGA/RGB Converter. The attached monitor must be able to display an RGB signal with the provided frequencies.



You can only use an RGB Monitor with a VGA-Signal if the Monitor is able to process the SYNC frequencies (for example, a monitor with HSYNC = 40-90 kHz may not work from VGA with 640x480 = 31,5 kHz).

RGB in/RGB out

The attached monitor must be able to display an RGB signal with the provided frequencies. In this mode, it might be necessary to switch off the automatic gain control (AGC) if your monitor does not blank the 'white pulse'.

RGB in/VGA out – SYNC Stripper

In this mode, the remote unit works as an additional SYNC stripper – the SYNC signals are stripped off from green, separated and presented as TTL-signals.



Depending on the technical design of the units, you receive at HSYNC-output a CSYNC signal (HSYNC and VSYNC mixed) and at the VSYNC-output a VSYNC-signal. Some types of VGA-monitors show distorted pictures, while receiving both CSYNC on HS and an additional VSYNC on VSYNC.

If you have a monitor that shows distorted pictures in this configuration, you can suppress the VSYNC -signal by removing jumper JP9 on the Remote unit (VRO). All monitors that show distorted pictures, because of this double signal, work well with a pure composite-signal (VSYNC disconnected).



A VGA-monitor only works as an RGB graphic adapter if the monitor is able to process the synchronization frequency of the video source (e.g. a multi sync-monitor with horizontal bandwidth of 30-90 kHz may not work with a WF470 graphic adapter with 15.625 kHz).

It is not possible to generate the special phase relations (of the VGA-standard) that are required by some types of dual scan monitors (LCD-panels, for example). In this mode, you may have to switch off AGC if your monitor does not blank out the WRI (White Reference Impulse) and shows it on screen.

RGB signals have a lot of different types of signal forms and combinations. For further information please contact our Technical Support. We will help you to find a solution for your application.

5.1 TFT Monitors

Use this procedure to correct for discrepancies in the video signal due to analog/digital video conversion by a TFT monitor. You do not need to follow this procedure if you have a CRT monitor connected because the video format is not converted.

1. Connect the Extender system and display the regular desktop in the desired screen resolution. Monitor Setup may vary depending on screen resolution and/or refresh rate. For different screen resolutions and/or refresh rates it might be necessary to follow this procedure several times.
2. Depending on the type of TFT, press the 'AUTO' Button on the monitor control panel or select *Auto Adjust* in the TFT Setup Menu. Refer to the manual supplied with your monitor for more information.
3. If the picture quality is not acceptable after the automatic adjustment, you might get enhanced results using an applicable test pattern display: go to Step 4. If the vertical stripes are sharp and without jitter or smearing, the adjustment has been successful. The setup is completed.
4. Download the test pattern from: <http://www.ihse.de/images/burst.htm> and store this file in a directory of your choice.
5. Select this graphic for the desktop background:
Start / Settings / Control Panel / Display / Backgrounds
6. Select it as a *tiled* display. Your desktop should now show fine, black and white, vertical stripes over the total background.
7. Depending on the type of TFT, press the 'AUTO' Button on the monitor control panel or select *Auto Adjust* in the TFT Setup Menu. Refer to the manual supplied with your monitor for more information.
8. If the vertical stripes are sharp and without jitter or smearing, the adjustment has been successful. Go to Step 10.
9. If the picture quality is not acceptable after the automatic adjustment, you will have to manually adjust the pixel clock and pixel phase (in this order). Please follow the instructions in your monitor's user manual.
10. Select a graphic of your choice for the desktop background:
Start / Settings / Control Panel / Display / Backgrounds

The Setup is complete.

5.2 Hints for Pixel Clock and Pixel Phase

Why do you need to adjust Pixel clock and Pixel phase (always in this order) when you are using a TFT screen?

This can be explained by means of a 'virtual' reduced system, which has only a few pixels and lines displaying a burst pattern (see above). The system would look like:

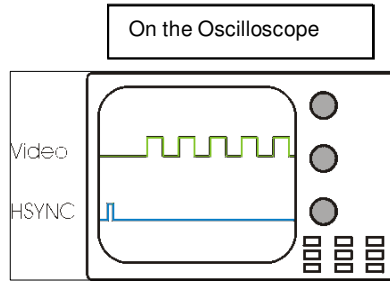
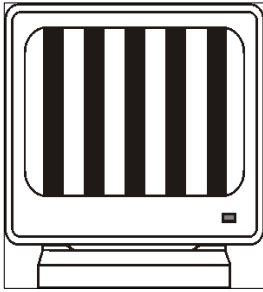

To display an analog picture correctly, the TFT must know Pixel Clock and Pixel Phase. To define these, it needs to calculate:

The exact center of each Pixel...

... the black 'shoulder' (the beginning of the picture), the number of pixels per line and the Pixel Phase (Middle of each Pixel)

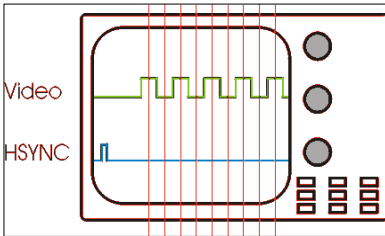

Wrong Pixel Clock

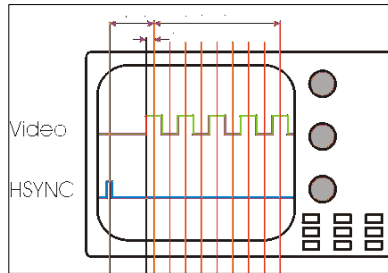

Wrong Pixel Phase

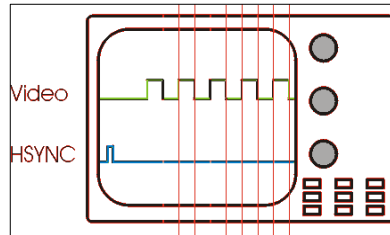
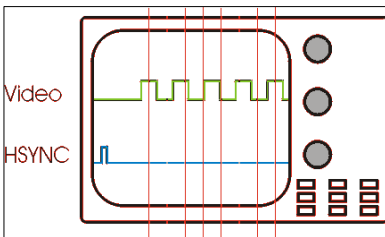

5.3 Manual Adjustment of Video Signals



CAUTION: This procedure applies to Remote Unit only with AGC=OFF! – do not attempt any adjustment of the Local Unit.

The level of the three video signals may be simultaneously adjusted with the Brightness control. If you open too far to “brighten”, the video signal increases on oscilloscope-CRT, and a part of the SYNC signals appears in the video signal, as shown in (a).

(a) Signal too light

(b) Signal too dark

(c) Signal OK

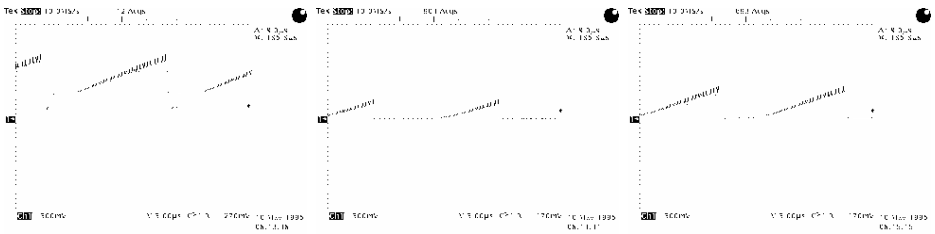

If you close too far to “dark”, the video signal decreases on the oscilloscope-CRT and a part of the signal is cut: see (b).

Adjust the brightness control so that it falls just before the signal: see (c).

Adjustment of amplitude

The amplitude of the colour channels depends on:

- The attenuation of the optical fibre
- The attenuation of the FO-connectors
- The position (gain) of the color control trimmer.

You may correct up to a 20% difference in signal amplitude in the three colour channels by setting the gain with the colour control trimmer. Adjust all channels (R, G, B) to the same value (amplitude app. 0.7Vpp..0.8Vpp = white). Since the attenuation exceeds, you may adjust the amplitude for all channels together, using the Contrast control (see above)

A difference greater than 20% indicates either a broken fibre or FO-connector.

6. Troubleshooting

There isn't a picture

Check the power supply connection at the Local unit. Is the *Device Ready* (Red LED) at the Local and Remote unit illuminated? If not, the internal power-supply may be damaged or there may be an internal error (see page 21).

Check that the Interconnection cable is connected at the Local Unit and the Remote Unit. Check the 7-segment display for error codes (see page 22).

There may be one or more broken fibres. Do NOT look into a fibre's end directly while it is connected to a Local or Remote unit! Check for broken fibres using a flashlight.

Are the cables of the recommended fibre type? If you used your own fibre optical cable (not supplied by us), please ensure that you have used 50 μ or 62.5 μ fibres. Other fibre-types and poly-fibres are not supported. Be sure, to have the Cable type jumper (see page 29) set accordingly.

Either HSYNC or VSYNC is missing; because of this, the power save function is enabled (EPA or TCO): Are the fibres for R, G, B swapped?

Running picture

The Monitor does not synchronize: are the fibres for R, G, B swapped?

instable screen picture

Do you use 62.5 μ fibres with a length below of 100m (app. 330 ft)? Please attenuate the optical budget by inserting optical fibre pigtails (see also **Using 62.5 μ fibre cable** on page 29)

Keyboard, as well as Mouse does not work

You have swapped the 1- and 2-fibre.

The fibres 1 and/or 2 are not connected to the Local or Remote unit.

There may be one or more broken fibres. Do NOT look into a fibre's end directly while it is connected to a Local or Remote unit! Check for broken fibres using a flashlight.

Are the cables of the recommended fibre type? If you used your own fibre optical cable (not supplied by us), please ensure that you have used 50 μ or 62.5 μ fibres. Other fibre-types and poly-fibres are not supported. Be sure, to have the Cable type jumper (see page 29) set accordingly.

Appendix A: Example Applications

This section illustrates some specific applications using Extender units:

- VTO2/VRO2 V6.00 KVM-Extender with speaker and microphone.

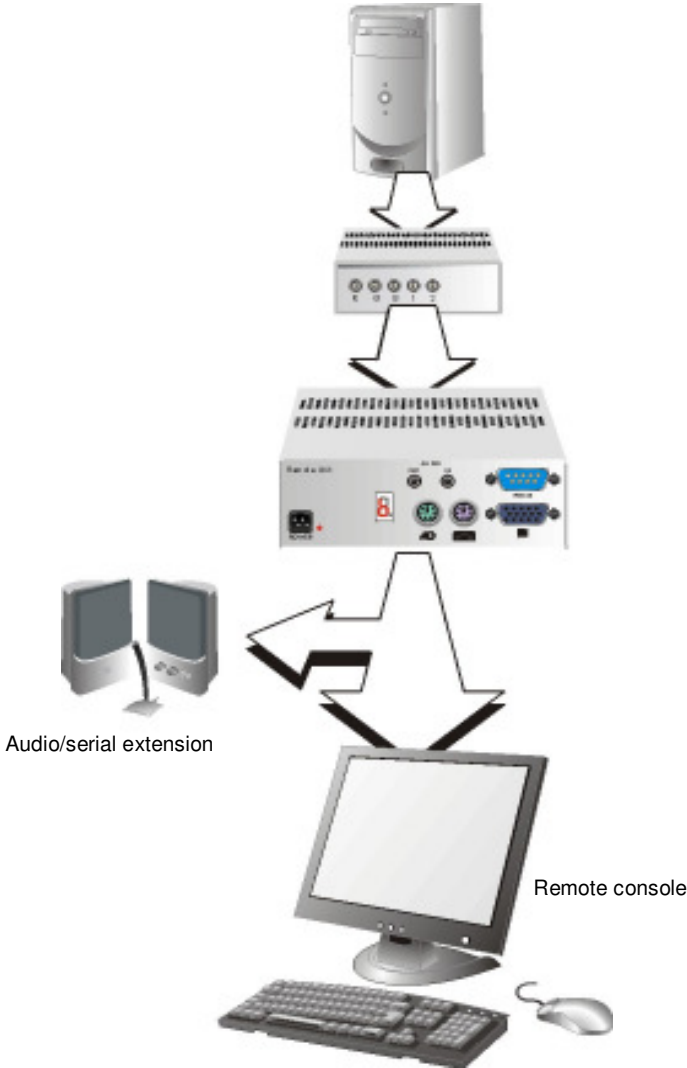

VTO2/VRO2 V6.00 KVM-Extender with speaker and microphone

APPENDIX A: EXAMPLE APPLICATIONS

- 4 CPU's – local outputs managed through a KVM- Switch and a single console. Remote Consoles up to 1000m away

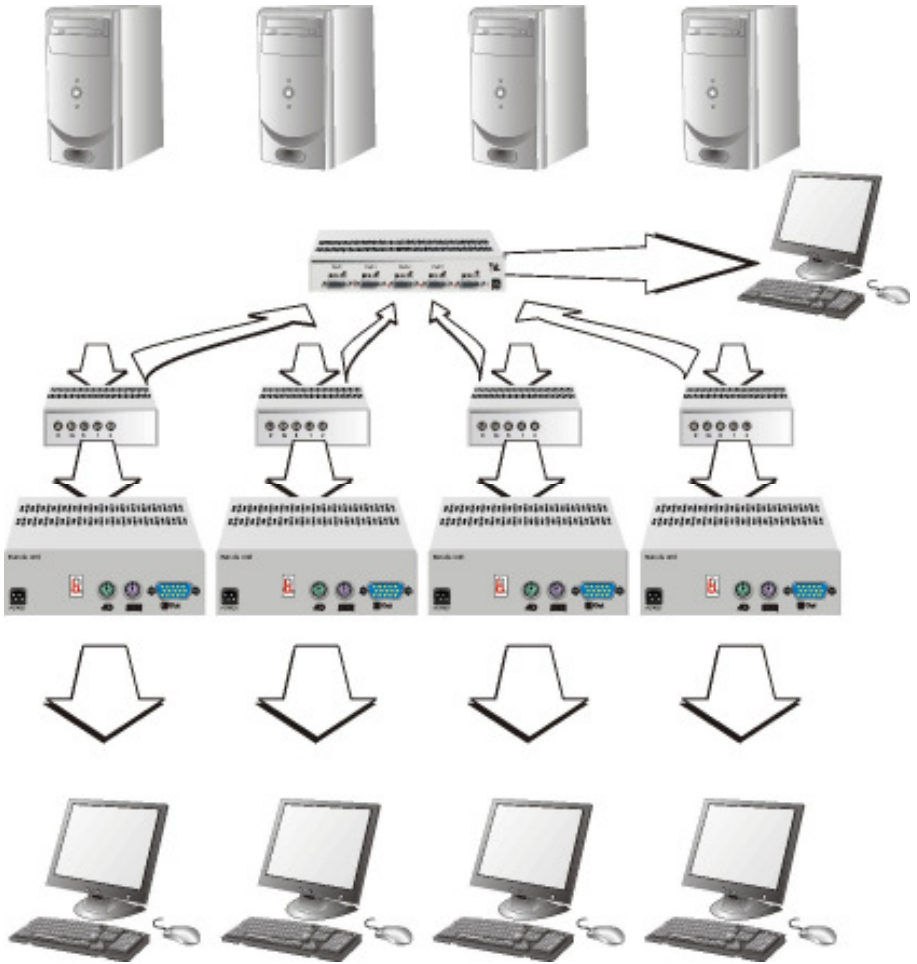

VTO2/VRO2 V6.00 KVM-Extender – local Consoles through a KVM- Switch

Appendix B: 19” Rack Mount Options

The VTO2/VRO2 V6.00 KVM- Extender units can be mounted in a 19” rack using the DDXi mounting kit.

This contains the following parts:

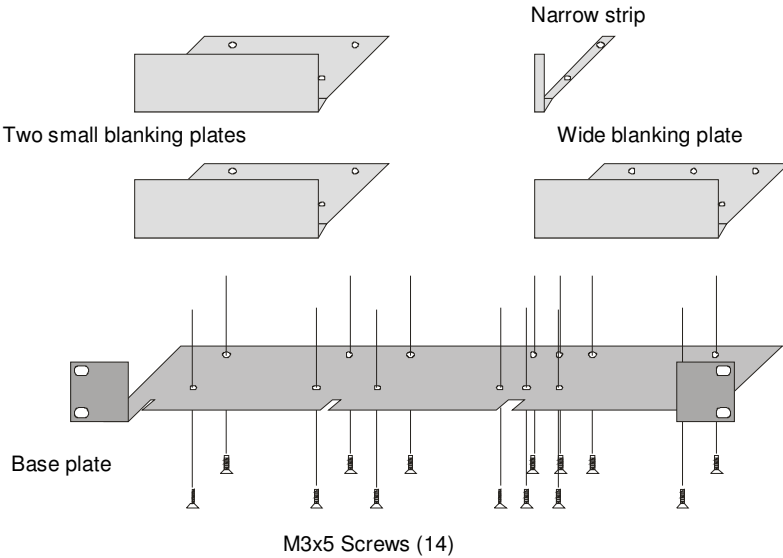

19” Rack Mounting Kit

To mount a unit:

1. Align the holes on the base plate with the vacant screw holes on the base of the VTO2/VRO2 V6.00 KVM extender unit.
2. Fasten the base of the unit to the plate of the mounting kit using the supplied screws.



Only use the supplied short screws; longer screws may cause damage to the PCBs.

3. Close the remaining gaps with blanking plates.

APPENDIX B: 19" RACK MOUNT OPTIONS

The kit allows you to mount various combinations of regular and double width housings. The VTO2/VRO2 V6.00 KVM-Extender comes in a single wide housing, so you can use one of the mounting options 1, 2 or 3:

1. One regular unit (using two small plates)

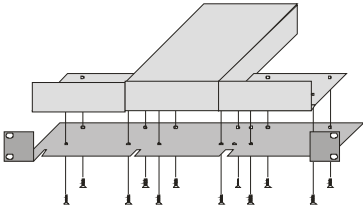

2. Two regular units (using one small plate)

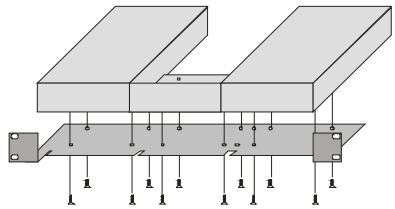

3. Mounting of three regular units

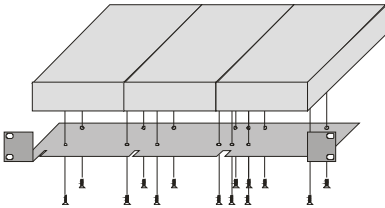

4. Mounting of one double width unit (using wide plate)

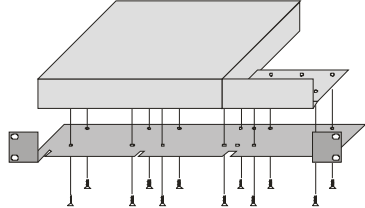

5. Mounting of double width and regular units (using narrow strip)

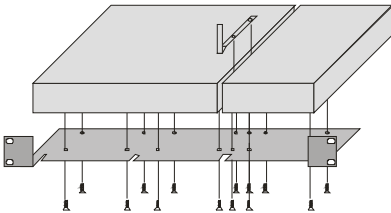

Appendix C: Audio/Serial Upgrade

The Audio/Serial Upgrade option consists of daughter boards that allow bi-directional stereo audio and a full-duplex serial data link to be sent across the regular interconnection cable in addition to keyboard, mouse and VGA/DVI video.

To set up the extender's audio and serial link, please follow all of the instructions detailed in this appendix. If you have any questions, contact Technical Support.

Serial Interface - Set Up and Operation

No setting up or user adjustments are required. Please note that on the Dual Access model, the serial link is always active.

Please bear in mind that the Remote Unit's serial port is wired as DTE (the same as that on a PC). To connect a serial printer (or other DTE rather than DCE device) to the Remote Unit, you will need a Null-Modem (crossover) cable between the Remote Unit and the printer.

A serial touch screen may be plugged directly into the Remote Unit.

Serial Interface - Handling Multiple Serial Devices

The extender's serial interface transmits/receives six signals (3 signals in each direction). Normally four of these signals are used for hardware handshaking (in addition to TX & RX). However, because each handshaking line can support signals up to 19,200 Baud it is possible to configure the serial interface to handle up to three simple 2-wire (Tx/Rx only) serial links. Select Xon/Xoff software flow control on the remote device and PC.

To do this you will need to construct a custom breakout cable. Please contact technical support for further information.

Audio Interface - Set Up and Operation

The audio interface is line-level and is designed to take the output from a sound card (or other line-level) source and be connected to a set of powered speakers at the other end of the link. Stereo audio may be transmitted either way across the link (simultaneously). No set up is required unless a microphone is connected to the remote unit.

Connect up the extender as follows:

1. Take the line-level output from your sound card (green connector) and connect to 'Line In' on the extender's Local Unit.
2. Connect a set of powered speakers to 'Line Out' on the Extender's Remote Unit.

Audio Interface - Using a Microphone

A microphone may be plugged into the 'Line In' connector on the Remote Unit.

There are two ways of setting up a microphone:

- The Local Unit's 'Line Out' connection should normally be wired to the microphone input (Red) on your sound card. The sound card should then be set up to provide additional amplification (+20dB). This is the preferred connection method.
- Alternatively, the Remote Unit itself can provide microphone amplification. To set this, open up the Remote Unit and locate the jumper labelled 'MIC' on the daughter board. Connect this jumper across the pins. The Local Unit's 'Line Out' connection should then be wired to 'Line In' (Blue) on your sound card.

If your microphone is already amplified, follow the second method but DO NOT install the amplification jumper in the Remote Unit.

Appendix D: Technical Support

If you determine that your VTO2/VRO2 V6.00 KVM Extender is malfunctioning, *do not attempt to alter or repair it*. It contains no user-serviceable parts. Contact Technical Support.

Before you do, make a record of the history of the problem. We will be able to provide more efficient and accurate assistance if you have a complete description, including:

- The firmware-revision level printed on the bottom of the Extender (very important, especially for keyboard and mouse problems); The VTO2/VRO2 KVM extender’s firmware revision level:

-

Version Number Format:

Board: ***xxLO/RE Myyy Pzzz Auuu Gvvvvvv***

Transceiver: ***C/M/S xx Pyy Mzz***

Keyboard/Mouse: ***P/U xx Vyyy***

- The nature and duration of the problem.
- When the problem occurs.
- The components involved in the problem—that is, what type of computers, what type of keyboard, brand of mouse, make and model of monitor, type and make of cable, etc.
- Any particular application that, when used, appears to create the problem or make it worse.
- The results of any testing you’ve already done.

To solve some problems, it might be necessary to upgrade the Extender’s firmware. If this turns out to be the case for your difficulty, our Technical Support technicians will arrange for you to receive the new firmware and will tell you how to install it.

Shipping and Packaging

If you need to transport or ship your VTO2/VRO2 KVM Extender:

- Package it carefully. We recommend that you use the original container.
- If you are shipping it for repair, please include the Unit’s external power supplies. If you are returning it, please include everything you received with it. Before you ship the Extender back to the manufacturer for repair or return, contact us to get a Return Authorization (RA) number.

Appendix E: Specifications

Power Requirements

<i>Voltage</i>	PSU: 90..240VAC-0.5A-47..63Hz/6VDC-2000 mA
<i>Power required</i>	Local Unit: approx. 8W Remote Unit without keyboard: approx. 8W Remote Unit with keyboard: approx. 9.5W

Interface

(Depending on type of device)

<i>Video Source/Monitor</i>	VGA up to 1280x1024@75Hz	
<i>Keyboard</i>	PS2	
<i>Mouse</i>	PS2 2-/3-button and wheel mice	
<i>Serial</i>	<i>Speed</i>	Up to 19200BAUD
	<i>Data format</i>	Format Independent, transparent
	<i>Handshake</i>	RTS, CTS, DTR, DSR are sent across link
<i>Audio</i>	<i>Description</i>	Bi-directional stereo audio link
	<i>Transmission Method</i>	Digitised virtually CD quality audio (16-bit, 38.4KHz)
	<i>Signal Levels</i>	Line-Level (5 Volts Pk-Pk maximum) @ 47kOhm
	<i>Connectors</i>	Local Unit: 2 x 3.5mm stereo jack socket (Line In & Line Out) 2 x 3.5mm stereo jack socket (Line/Mic In& Line Out)
	<i>Microphone Support</i>	A microphone may be connected to the Remote Unit. Pull-up resistor provides bias for condenser microphone. Option to set microphone amplification to +17dB.

Maximum Length of Interconnection Cable

<i>50µm Multimode</i>	3250ft (1000m)
<i>62.5µm Multimode</i>	3250ft (1000m)

VTO2/VRO2 V.6.00 –5 STRAND KVM-EXTENDER

Type of Interconnection Cable

<i>K236-9W</i>	3 Fibres Multimode, e.g. I/AD(ZN)H 4G50 (In-house OR Outdoor Breakout cable)
<i>K234-9W / K235-9W</i>	5 Fibres Multimode, e.g. A/DQ(ZN)B2Y 4G62,5 (Outdoor Breakout cable with protection against rodent)

Optical Elements

<i>Center Wavelength</i>	850nm
<i>Optical budget total (typical)</i>	-5 dBm

Size and Shipping Weight

<i>VTO2/VRO2 – V 6.00</i>	Remote/Local Unit: 7.1”x5.2”x1.7” (180x133x44mm) Weight: 2.6lb (1.2kg) each
<i>Shipping box</i>	Shipping Box: 18.1”x9.8”x4.7” (460x250x120mm) Weight: 9.5lb (4.3kg)

Environmental

<i>Operating Temperature</i>	41 to 113°F (5 to 45 °C)
<i>Storage Temperature</i>	-13 to 140°F (-25 to 60 °C)
<i>Relative Humidity</i>	max. 80% non-condensing

Appendix F: Connectors

VTO2/VRO2 V6.00 KVM-Extender Connector Pin outs

VGA female (Signal Output)

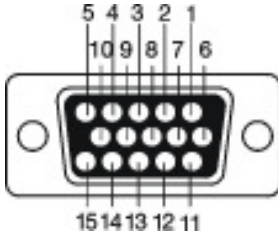

VGA male (Signal Input)

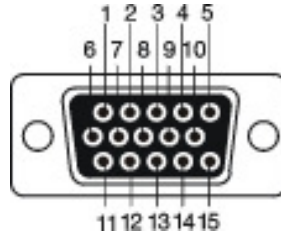

Pin	Signal	Pin	Signal	Pin	Signal
1	RED-	6	RED GND	11	
2	GREEN	7	GREEN GND	12	
3	BLUE	8	BLUE GND	13	HSYNC
4		9		14	VSYNC
5		10	SYNC GND	15	

Keyboard/Mouse female (Signal Input/Output)

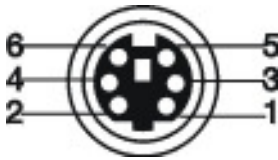

Pin	Keyboard	Pin	Mouse
1	KBD-DATA-	1	MOUSE-DATA-
2		2	
3	KBD-GND	3	MOUSE-GND
4	VCC (+5V)	4	VCC (+5V)
5	KBD-CLCK	5	MOUSE-CLCK
6		6	

VTO2/VRO2 V.6.00 –5 STRAND KVM-EXTENDER

RS232 (only device K234-9W with serial/Audio Upgrade)

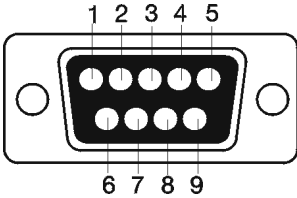

9 pin DSUB female (Local Unit)

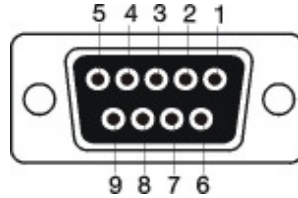

9 pin DSUB male (Remote Unit)

<i>Pin</i>	<i>Signal</i>
1	Not connected
2	RxD
3	TxD
4	DTR
5	GND
6	DSR
7	RTS
8	CTS
9	Not connected

Power

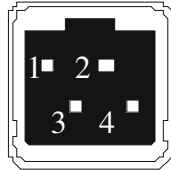

<i>Pin</i>	<i>Signal</i>
1	GND
2	Earth
3	n.c.
4	+6VDC
Housing	Shield

NOTES

NOTES