

- Supports DVI-I Input (VGA or DVI)
- Supports DVI-I Output (VGA or DVI) on each channel independently
- Resolution up to maximum 1920x1200@60Hz
- 4port: Desktop Device, 19"-Rack mountable
4port/8port: 19"/1U Device, also suitable for desktop purposes



DVIPLEX

DVI 4PORT/8PORT SPLITTER

DVIPLEX DVI 4/8port Splitter



| | |
|-------------------|--|
| Input Interface | DVI-I (SingleLink) – VGA or DVI |
| Output Interface | DVI-I (SingleLink) – VGA or DVI – not HDCP compliant |
| Output Resolution | 1920x1200@60Hz, resolution up to 1280x1024 at least 75Hz |
| Power Supply | 4port desktop: Universal Switchmode PSU (90-240V Input) 4port/8port 19"-device internal PSU (90-240V Input) |
| Dimensions | 4port desktop device: 260 x 170 x 41 mm (19" Rackmount Kit and mounting brackets available) 4port/8port 19"-device: 19"/1U |
| Upgradable | Onboard Flash |

DVI 4port/8port Splitter

Some customers, especially industrial users, need to display screen data not only on one but on two or more screens (TFT's) simultaneously.

Using the DVIPLEX 4port/8port Splitter it is possible now, to display the data of a modern DVI graphic card on two monitors (TFT's) simultaneously - in an absolute brilliant quality – because of the digital data format there is no loss in signal quality possible!

A special property makes this device to your solution for all purposes: It does not only accept the signals of a VGA graphic card as well as those from a DVI graphic card – on each output channel – independent from all the others, you can attach either a DVI-Flatscreen (TFT) or a traditional VGA-CRT. This means, there is a built in signal translator for each channel!

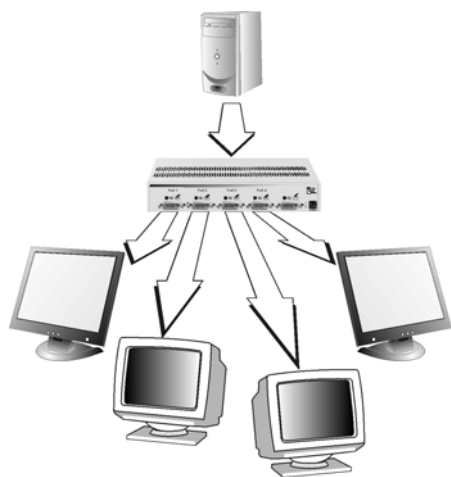

Installation Sample

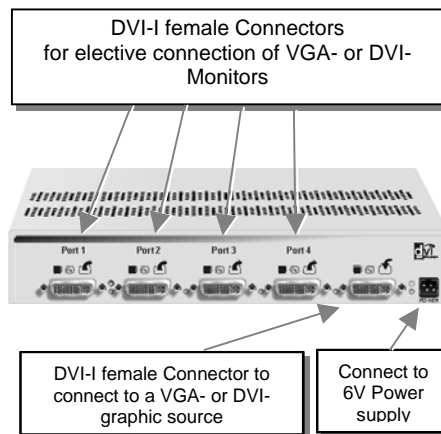

If you connect your Splitter to a DVI graphic source, it is not required to do any Setup Configurations, to make it running. If you connect to a VGA graphic source, the built-in Auto-Adjust function allows best video performance. As like using flatscreens (TFT's) in some occasions it might be necessary, to manually adjust some parameters like Pixelclock, Pixelphase, Brightness, etc. An integrated, comfortable OSD (On Screen Display) Utility makes it easy to do this.

In some special occasions, it can be necessary, to redefine the source for the DDC- Information for the CPU. The factory setting defines the DDC of the attached Screen on Channel 1 to the Master. If this setting does not satisfy your requirements (e.g. because the attached displays support different DDC Information) the DDC can either be switched off or can be taken from the internal DDC table.

Highlights

- Perfect picture quality on all resolutions
- Output: Supports on each Output Connector – independent from all other connectors – alternatively the traditional VGA Signal or the new DVI Video Interface
- Input: Supports alternatively the traditional VGA Signal or the new DVI Video Interface
- Signal Translation: The device is able, to make a Signal Translation from VGA to DVI or from DVI to VGA
- 4port desktop device: 19" rack mountable through rack-mount-kits
4port/8port 19"-device: also suitable for desktop purposes
- also available with switchable outputs
- internal DDC Table of supported screen resolutions:

| | horizontal | vertikal |
|-----------------|------------|----------|
| VGA | 640 | 480 |
| Vesa Standard | 720 | 400 |
| IBM, VGA, XGA2 | 720 | 400 |
| Vesa Guidelines | 800 | 600 |
| Mac Mode | 832 | 624 |
| Vesa Guidelines | 1024 | 768 |
| SUN Mode | 1152 | 870 |
| TV | 1280 | 768 |
| Vesa Standard | 1280 | 960 |
| Vesa Standard | 1280 | 1024 |
| SGL | 1600 | 1024 |
| Vesa Standard | 1600 | 1200 |
| TV | 1920 | 1080i |
| WUXGA | 1920 | 1200 |